

Shear performance of novel disk-type porous foam metal magneto-rheological (MR) fluid actuator

X. H. LIU

School of Mechanical and Automation Engineering, Shanghai Institute of Technology, China
School of Mechatronics and Automation Engineering, Shanghai University, China

The paper presents a new disk-type porous foam metal magneto-rheological fluid actuator and investigates the shear performance experimentally. The actuator has the following characteristics, MR fluid is stored in porous foam metal, in action of magnetic field, MR fluid will be extracted out from the porous foam metal and fill up the shearing gap, and produce the MR effect. The influence of the materials with different relative permeability, the current, the shear rate and the gap on the shear performance are investigated and analyzed experimentally. The experimental results show the volume of MR fluid extracted from porous foam metals is one of the critical factors for the shear torque of the actuator. Last, to validate the effect of volume on the shear torque, the experiment is studied by adding the different volume of MR fluid on the gap.

(Received August 2, 2010; accepted September 15, 2010)

Keywords: Shear performance, MR fluid, Disk-type magneto-rheological fluid actuators, Porous foam metal

1. Introduction

Magneto-rheological fluids (MRF) are stable disperse systems composed of two phases, such as magnetic particles (of size 3-10 μm) and hydrocarbon. As a kind of functional materials, these fluids are dramatically influenced by external magnetic fields and can change from the liquid state to semi-solid state in milliseconds [1] [2]. But, if no external magnetic field is applied, these liquids will behave as any other liquids. The characteristics of MR fluid make it possible to be applied on the vehicles, engineering structures and other fields.

In recent decades, its characteristics as tribological performance, free surface and normal response are studied widely [3-5]; however, a barrier on applications to widespread commercial acceptance is the relative cost of a controllable MR fluid device compared to conventional passive devices. Carlson [6-7] specified the major cost factors including: seals, surface finish of the piston rod, precision mechanical tolerances, and the volume of MR fluid and introduced the idea of using sponge to contain MR fluids. The sponge which wraps around the piston of the damper keeps the MR fluid in position without seals. However, the sponge idea suffers from some major problems, the relatively small magnetic field strength and the durability of sponge.

As the better mechanical strength, the smaller clearance and much higher magnetic field strength can be guaranteed than the matrix sponge, the disk-type porous foam metal magneto-rheological fluid actuator is developed. The shear performance is studied for the different porous foam metal, the current in loop, and gap size between shearing disks.

2. Experiment setup and methods

2.1 Materials preparation

The MR fluid is MRF-132AD of Lord Corp., which mainly consists of magnetizable particles in micron-sized, hydrocarbon based oil and other additives. The size and shape distributions of the iron particles examined by scanning electron microscopy (SEM) are found to be nearly spherical and typical dimensions around 1–5 μm in diameter, from [9], the magnetic and mechanical characteristics will be obtained.

The porous foam metal with the various porosity and rigidity are obtained by changing the machining current density, which consist of Fe alloy, Ni alloy or copper alloy, the constructor used is as Fig. 1 (SEM), here, it can be considered as open-cell; the pore size of porous foam metal is from 100 μm to 550 μm , The magnetic characteristics of these porous foam metals are tested by VSM as shown is Table 1. From Table 1, the initial relative permeability of porous foam metal Fe is the biggest one of them, and then Ni, the Cu is the smallest.

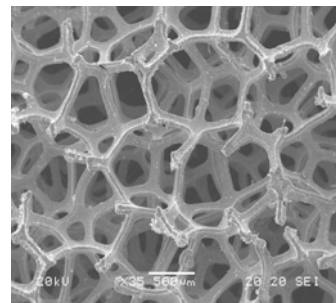

Fig. 1. The structure of porous foam metal.

Table 1. Parameters of porous foam metal.

Porous foam metal	The initial relative permeability μ_r	Thickness (mm)	Porosity (PPI)
Cu	1	1.6	110
Ni	1.5	1.6	110
Fe	2.8	1.6	110

2.2 Disk-type porous foam metal MR fluid actuator and test rig

The sketch of disk-type porous foam metal MR fluid actuator is shown as Fig. 2, porous foam metal is attached on the surface of lower shearing disk 4 gap size, h , is defined as the distance between the surface of the porous foam metal and the upper disk Adding up MR fluid to porous foam metal, in help of vacuum pump with the minimum pressure of 0.06 Pa, keep this pressure for 5 minutes, and then repeat it, MR fluid is considered to fill up the porous foam metal. When the current is zero, that is, the outer magnetic field is off, MR fluid is stored in the porous foam metal, and no appearances in the gap, if the current is on, MR fluid in the pore of porous foam metals will be extracted and begin to fill the gap between the upper surface of porous foam metal and the upper shearing disc, in the action of magnetic field, the MR effect will be produced.

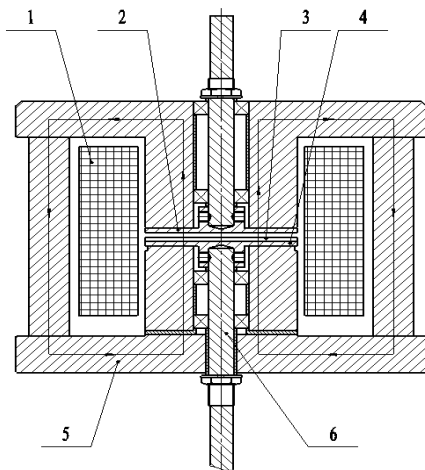

1: Coil, 2 and 4: Parallel shear disk 3: Porous foam metal, 5 and 6: Highly permeable materials (20# steel)

Fig. 2. Schematic of porous foam metal MR fluid actuator.

3. Experiment results and discussion

Fig. 3 is the relationship between shear torque of actuator and shear rate, the materials is porous foam metal

Fe. From Fig. 3, shear torque will keep stable with the increased shear rate. Fig. 4(a) to (c) is the relationship between shear torque and the current for different gap sizes and materials, respectively. Figs. 6 are comparison in torque for under the same gap size in current 0.9 A. Fig. 4 shows that the torque increases quite rapidly at initial state with the increased current. However, the rate of torque increasing becomes much milder at above 0.9 A, which is probably due to the magnetic saturation of MR fluid, that is, when current is 0.9 A, MR fluid has arrived yield stress.

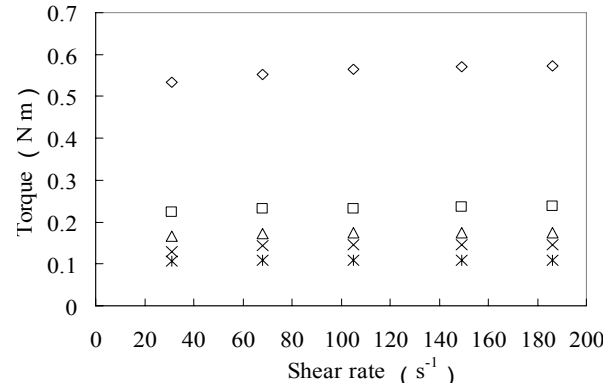
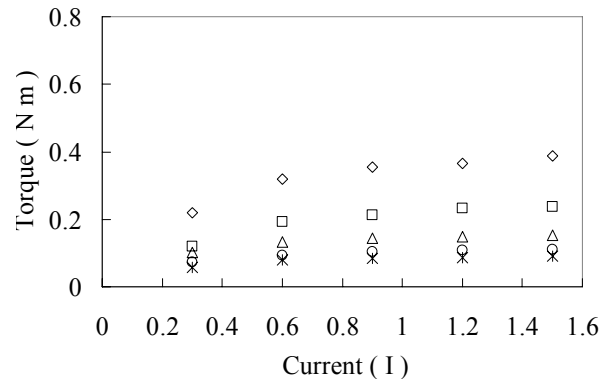

Fig. 3. Shear torque vs. shear rate (Current: 1.00 A)

(Gap: □0.48 mm □0.76 mm △1.00 mm ×1.16 mm *1.34 mm)

Fig. 4 shows that for the same gap size from 0.48 to 1.34 mm, the shear torque of porous foam metal Cu is always above Fe and Ni. To the last two porous foam metals, Fe and Ni, with the gap size increased, When it is above 0.76 mm, the torque is close to each other, which maybe results from the followings two reasons: different magnetic flux density in MR fluid and shear gap. As to Cu, the volume extracted from porous foam metal is always far larger than the Fe and Ni.

Besides, Fig. 4 and 5 show that under the conditions on the same porous foam metals, with the increased gap, the torque will decrease obviously.



(a) Porous foam metal Fe

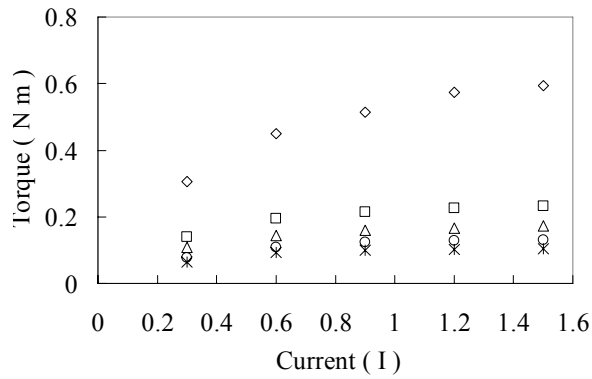

(b) Porous foam metal Ni

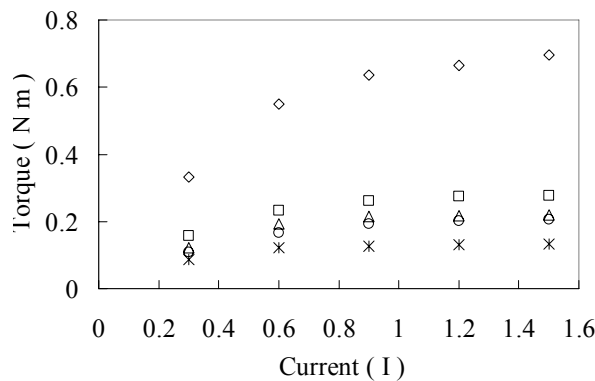

(c) Porous foam metal Cu

Fig. 4. Torque of porous foam metal MR fluid actuator. Torque vs. current (\square 0.48 mm \square 0.76 mm Δ 1.00 mm \circ 1.16 mm *1.34 mm). Thickness of porous foam metal 1.6 mm, porosity 110 ppi, shear rate 46 s^{-1} .

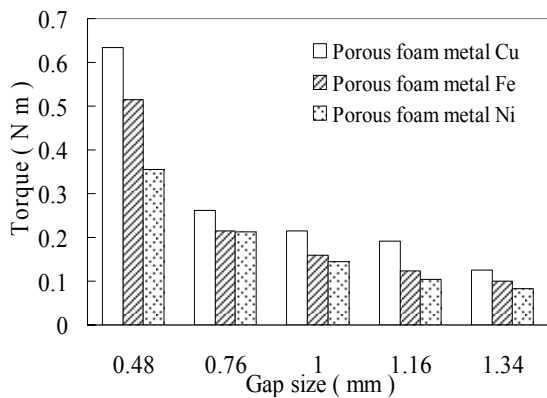
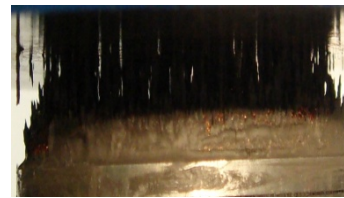

Fig. 5. Torque vs. gap size thickness 1.6 mm, porosity 110 ppi, shear rate 46 s^{-1} , current 0.9 A.

According to [5], the volume of MRF drawn out from the porous foam metals is related to the magnetic flux density in MR fluid. When the magnetic field pass through the porous foam metal with magnetizable metal, as Fe or Ni, the magnetic field shield will occur, so the magnetic

flux density in MR fluid is inversely related to the magnetic permeability, that is, the volume extracted from porous foam metal, the Cu is the most, which also can be seen from Fig. 7 intuitively, it is in the same conditions and current.

The experiment shows that when gap size ranges from 0.48 to 1.34 mm, the extracted volume of MR fluid from porous foam metal is dominant. Hence, the torque of MR fluid actuator using porous foam metal Cu is always the largest, as a collective result of the two reasons, the torque of Ni is close to Fe, which means the effects of both factors are about the same. In order to validate the effect of different volume on shear torque, by adding MR fluid on the surface of porous foam metal Fe filled with MR fluid, the experiment result is shown as Fig. 6.



a) Porous foam metal Cu

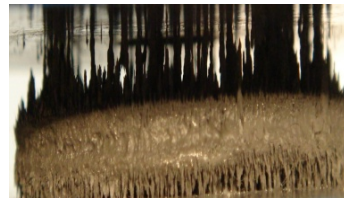

b) Porous foam metal Fe

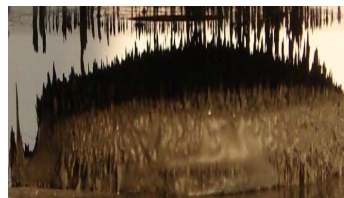

c) Porous foam metal Ni

Fig. 6. The volume of MR fluid rising from porous foam metal.

By calculation, when the added volume of MR fluid is above 2.8 ml, the gap is filled up with the added MR fluid. Fig. 7 shows in the conditions of no added MR fluid, the shear torque of porous foam metal Fe is the smallest, and with the volume increased, its shear torque increases most obviously, when the gap is filled up with added MR fluid, the difference between them become very small, but it can be seen shear torque of porous foam metal Cu is smallest, which probably results from the magnetic flux density in the gap.

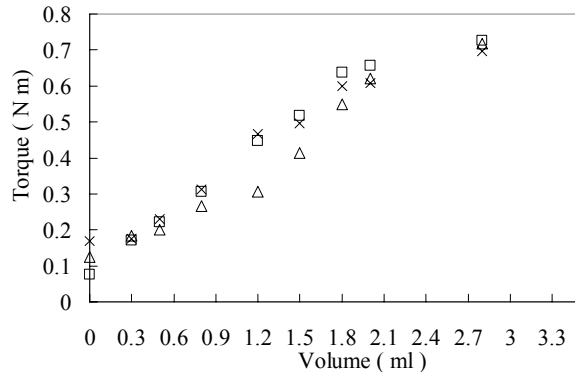

Fig. 7. Shear torque vs. added volume (□ Fe △ Ni × Cu)
(Current: 0.5 A, gap size: 1 mm, shear rate: 53.4 s⁻¹).

In order to provide the more theory explanations for these results, the calculation for shear torque is built up. As the characteristics of non-Newton fluid, the mechanical model of MR fluid is described by Bingham model, that is, $\tau = \tau_y + \eta\dot{\gamma}$, and here, τ_y is the shear yield stress of MR fluid, which is mainly related to the magnetic flux density in MR fluid, η is the viscosity of MR fluid, and which can be obtained from [9], thus, the shear torque can be written

$$T = 2\pi \left[\frac{r^3 \tau_y}{3} + \frac{\omega \eta r^4}{2h} \right] \quad (1)$$

Equ. (1) shows the relationship between the shearing torque and the radius of shear disk r , the gap size h , the rotating rate and the magnetic flux density. if the gap size h is a constant and the current is 1.0 A, shear torque is mainly decided by the shear yield stress of MR fluid. So with the shear rate increased, the shear torque is stable. When the gap is filled with MR fluid, the relationship between shear torque and magnetic flux density can be obtained, according the experiment conditions as Fig. 7, if the gap size is 1 mm, thus, the maximum of shear torque produced by MR fluid can be calculated in theory is about 2.3 N m, in Fig. 7, maximum is about 0.74 N m, which mainly results from the porous foam metal. First, the thickness of porous foam metal will increase the gap size between the two shear disks; secondly, during the shearing process, even the gap is filled up with MR fluid, but a large quantity of air bubble in the shearing chain will reduce the MR effect.

4. Conclusions

A new disk-type porous foam metal magneto-rheological fluid actuator is presented and investigated experimentally in the paper. As the magnetic flux density in MR fluid for different porous foam metal, porous foam metal Cu can provide the biggest, and the volume is also bigger than the other two porous foam metals, the influencing factors for shear torque are analyzed, and for the gap size from 0.48 mm to 1.34 mm, the effect of volume extracted from porous foam metal on torque is most obviously, from the shear torque of them, the porous foam metal Cu is the best choice. Nevertheless, as to the shear torque of porous foam metal MR fluid damper, the results show it has the obvious MR effect, and maybe the magnitude of shear torque need improve. But compared with the sponge MR fluid damper, as provided by Carlson, the porous foam metals have the advantages as wearable, which maybe provided the new methods for design the low-cost MR fluid damper.

Reference

- [1] M. R. Jolly, J. W. Bender, J. D. Carlson, *Journal of Intelligent Material Systems and Structures*, **10**(1), 5 (1999).
- [2] O. Ashour, C. A. Rogers, W. Kordonsky, *Journal of Intelligent Material Systems and Structures*, **7**(2), 123 (1996).
- [3] P. L. Wong, W. A. Bullough, C. Feng, S. Lingard, *Wear*, **247**, 33 (2001).
- [4] Y. T. Chan, K. P. Liu, P. L. Wong, W. A. Bullough, *Journal of Physics: Conference Series*, **149**, 012041 (2009).
- [5] X. H. Liu, P. L. Wong, W. Wang, K. P. Liu, *Journal of Physics: Conference Series* **149**, 012072 (2009).
- [6] J. D. Carlson, *Proc. 8th Int. Conference on Electrorheological (ER) Fluids and Magneto-rheological (MR) Suspensions*, 621-628, Nice, France, 2001.
- [7] Michael J. Chrzan, J. David Carlson, *MR Fluid Sponge Devices and Their Use in Vibration Control of Washing Machines*, *Proceedings of the 8th Annual Symposium on Smart Structures and Materials*, Newport, Beach, CA, March 2001.
- [8] Lord Corp. Datasheet of MRF-132AD, <http://www.lordfulfillment.com/upload/DS7012.pdf>
- [9] Y. T. Chan, *Response of Excited MR fluid along the field direction [D]*, City University of Hong Kong, 2009.

*Corresponding author: liu_xuhui79@163.com