

On time-domain OFDM channel estimation: use of pilots correlation for digital video broadcasting (DVB) cable receiver

A. M. KHAN*, VARUN JEOTI

Department of Electrical and Electronic Engineering, University Technology PETRONAS, Tronoh, Perak Malaysia

In this paper, an improved OFDM time domain channel estimation algorithm is proposed for (DVB) Cable receivers. The algorithm exploits time domain-pilot correlation (TD-PC) to estimate the channel impulse response (CIR). In this method, a certain combination of positive and negative sub-pilot tones is used to generate the null carriers in each OFDM symbol. The first set contains all positive periodic carriers; while the second contains negative carriers at null positions. Then we take advantage of these positive periodic sub-pilot carriers in time-domain correlation with received signal which gives rise to zero correlation of data to positive pilot subcarrier over the length of cyclic prefix. The performance of proposed TD-PC algorithm is evaluated under DVB-Cable-2 fading channel models in digital cable TV receivers. Simulation results show that the proposed algorithm provides better accuracy in term of Mean Square Error (MSE) over conventional time and frequency domain channel estimators. It is shown that proposed TD-PC algorithm has a comparable performance to Cramer-Rao bound (CRB) in low signal to noise ratio (SNR) regime.

(Received April 10, 2015; accepted May 7, 2015)

Keywords Orthogonal Frequency Division Multiplexing, Time Domain-Pilot Correlation, Discrete Fourier Transform

1. Introduction

In this era of multimedia applications, a digital TV demands the high quality video, audio and data broadcasting services in rapidly changing environment. In cable TV reception, a transmitted signal travels to the digital TV receiver by undergoing many detrimental effects that corrupt the signal and often place limitations on the performance of the system. Mainly, these effects are impulsive noise and echoes. The impulsive noise caused by the central heating, cooker ignition and light switches. However, echoes are caused by the reflection of the signal at connectors, damaged cables and incorrectly terminated cables. Therefore, an efficient, low complexity and precise channel estimation strategy is very important to keep track of the distorted channel, which is one of the challenging issues in digital TV receivers.

Orthogonal frequency division multiplexing (OFDM) has received an extensive interest in wire/wireless communication system due to its robustness to multipath delay in channel estimation and equalization. OFDM modulation technique uses a cyclic prefix (CP), which eliminates the inter-symbol-interference (ISI) between OFDM symbols [1]. Moreover its high data rates are available without having to pay for extra bandwidth [2, 3]. These features have been adopted by Digital Video Broadcasting Terrestrial/Cable (DVB-T/C) for signal transmission [4].

In Digital cable receivers, several studies have been conducted on the use of pilot-aided channel estimation in frequency domain, but little attention has been paid to estimation in time domain because the performance of data

detection and equalization is considered best in the frequency domain.

Furthermore, channel frequency response (CFR) does not require an extra Fast Fourier Transform (FFT) operation to convert the channel impulse response (CIR) into CFR. In frequency domain, channel frequency response is estimated at each pilot, and then these estimates are interpolated using different methods. Popular frequency domain techniques reported in literature utilize Least Squares (LS) and Minimum Mean Squared Error (MMSE). LS is considered as the simplest estimation method, but it is very sensitive to noise. This weakness is overcome by MMSE but at the expense of added complexity [5].

Although, little attention has been paid to time domain methods but arising to the fact that the number of channel taps in time domain is fewer as compared to frequency domain, leads one to try and develop in time domain channel estimation. Moreover, estimation in the time domain is not affected by the loss of orthogonality that can occur through the FFT transformation due to imperfections in the channels (e.g., carrier offset) that cause Inter Carrier Interference (ICI) [6]. Therefore, these features of CIR estimation provide a robust basis for estimating the channel taps in time domain.

In [7,8], it has been shown that, by exploiting the autocorrelation alone, an efficient and low complexity SNR estimation can be achieved in time domain. Similarly, in [9], a frequency-domain pilot time-domain correlation (FPTC) is proposed, where windowing approach is used to generate the null carriers in frequency domain (band limitation effect). Therefore, a high

computational complexity of deconvolution operation is required to estimate the channel taps in time domain. It is shown in [10], that Frank's windowing method improves the mobile receiving performance of FPTC method.

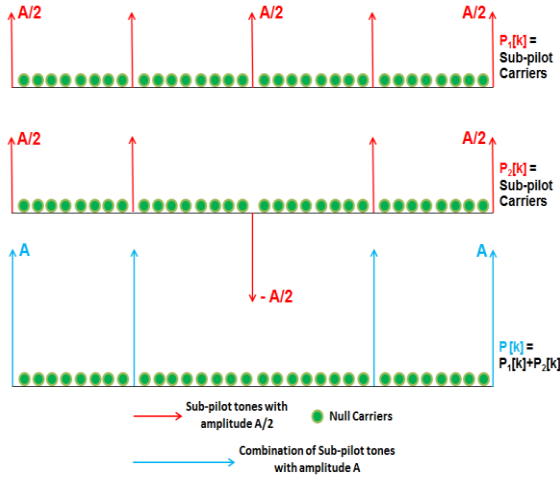

Fig. 1. Combination of sub-pilot carriers for proposed (TD-PC) method.

However the complexity of deconvolution still exists in the system. In order to overcome this drawback, a low complexity FPTC-based DFT method is proposed in [11], where DFT and IDFT computation is used to obtain the channel taps in time domain. Similarly in [12], DFT-based channel estimation is shown to estimation accuracy compared to conventional frequency domain (LS, MMSE) methods. Despite the popularity and efficiency of time domain DFT method, it not only suffers the leakage problem from non-significant channel taps but also requires extra computation of IDFT and DFT. It turns out that correlation of received signal in time domain can be fruitful to improve the MSE, but complexity should be kept low. Therefore the scope of this work is to improve the detection of significant channel taps in time domain channel with low computational complexity by using a correlation approach.

In this paper, we propose a time domain channel estimation scheme for DVB-Cable OFDM systems. The receiver of the proposed method assumed that frequency domain pilots with nulls are generated by a certain combination of positive and negative sub-pilot carriers in each OFDM symbol. The impulse response of channel is obtained by exploiting a cross-correlation between received signal and positive periodic pilot carriers. Then we take the advantage of these positive periodic carriers in time-domain correlation with received signal which gives rise to zero correlation of data to positive sub-pilot sequence over the length of cyclic prefix. In order to evaluate the accuracy and robustness of proposed method it is proposed to be compared with minimum unbiased variance estimator (CRB).

This paper has been organized in the following way. Section 2 explains the proposed time domain-pilot

correlation (TD-PC) method. Simulation parameters are presented in Section 3. Results and analysis are discussed in Section 4. Section 5 addresses the computational complexity analysis. Conclusion of the work is presented in Section 6.

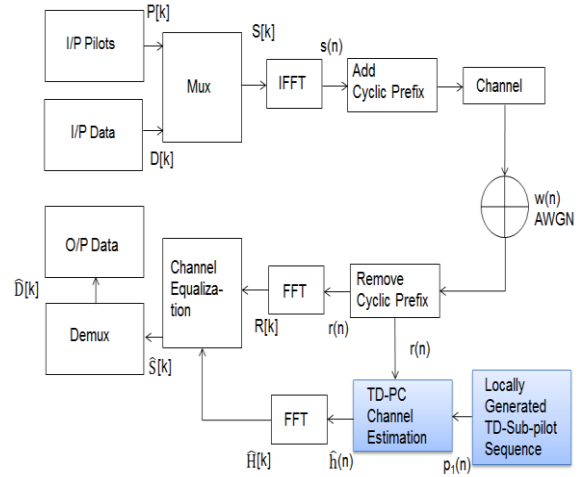

Fig. 2. Proposed OFDM baseband transceiver model.

2. Proposed Time Domain-Pilot Correlation (TD-PC)

In order to improve the performance of DFT-based estimator, an improved and efficient time domain channel estimator is presented. Proposed method differs from the conventional FPTC in the following way: The receiver assumes that the frequency domain pilots with null are generated by a certain combination of positive and negative sub-pilot subcarriers. The positive sub-pilot subcarriers are all positive periodic carriers and they carry no null subcarriers. While the negative sub-pilot carriers have negative subcarriers at null subcarrier locations. In order that both sub-pilot carrier sets have equal energy, we further propose to redistribute subcarrier power among both at all locations as shown in Fig. 1. In proposed method, the impulse response of the channel is estimated by using a cross-correlation between received signal $r(n)$ and locally generated positive periodic sub-pilot sequence $p_1(n)$, as shown in Fig. 2. The block diagram for proposed OFDM baseband transceiver model can be illustrated in Fig. 2, which involves the following steps:

2.1 Proposed positive and negative sub-pilot carriers

- Consider a OFDM transceiver, in which the receiver assumes that the pilot carriers $P[k]$ with null, can be expressed as a combination sub-pilot carriers $P_1[k]$ and $P_2[k]$, such that

$$P[k] = P_1[k] + P_2[k] \quad (1)$$

The idea behind the combination of two sets of sub-pilot tones is to generate the null carriers at their respective positions, as shown in Fig. 1. The first set contains all

positive periodic carriers; while the second contains negative carriers at null positions. Therefore, frequency domain sub-pilot tones $P_1[k]$ and $P_2[k]$ can be expressed as:

$$P_1[k] = \begin{cases} A/2, & k = N_F c \\ 0, & k = N_F c + d \end{cases} \quad (2)$$

where

c and d are integers, $0 \leq d \leq N_F - 1$, $0 \leq c \leq N_p - 1$, N_F is the pilot spacing and A is the unipolar BPSK modulated sub-pilot carrier.

N_p is the total number of pilot carriers used in channel estimation; and

$$P_2[k] = \begin{cases} -A/2, & (MP - NP + 1 \leq k \leq MP + NP) \\ P_1[k], & \text{otherwise} \end{cases} \quad (3)$$

where

$(MP = N_{FFT}/2)$ is the middle position of N_{FFT} ,

$(NP = N_{FFT}/32)$ represents the null position.

From Fig. 2, the frequency domain discrete transmitted signal $S[k]$ is given as:

$$S[k] = D[k] + P[k] \quad (4)$$

where $D[k]$ is the 16 QAM- modulated data symbol.

- Then $IFFT$ is applied on $S[k]$ samples which transform frequency domain samples $S[k]$ into time domain samples $s(n)$ which can be shown as:

$$s(n) = IFFT\{S[k]\} = \frac{1}{\sqrt{N_{FFT}}} \sum_{k=0}^{N_{FFT}-1} S[k] e^{j2\pi kn / N_{FFT}} \quad (5)$$

$n = k = 0, 1 \dots N_{FFT} - 1$

Similarly,

$$d(n) = \frac{1}{\sqrt{N_{FFT}}} \sum_{k=0}^{N_{FFT}-1} D[k] e^{j2\pi kn / N_{FFT}} \quad (6)$$

$$p(n) = \frac{1}{\sqrt{N_{FFT}}} \sum_{k=0}^{N_{FFT}-1} P[k] e^{j2\pi kn / N_{FFT}} \quad (7)$$

Therefore, the time-domain transmitted signal $s(n)$ can be written as:

$$s(n) = d(n) + p(n) \quad (8)$$

- Finally, after adding a guard band, signal is transmitted through a multiple echoes channel $h(n)$, which can be expressed as:

$$h(n, \tau) = \sum_{i=0}^{L-1} h_i e^{-j\theta_i} \delta(\tau - \tau_i) \quad (9)$$

where h_i is the i^{th} complex path gain, θ_i is the i^{th} phase, τ_i is the corresponding normalized path delay and L is total number of channel echoes. Without loss of generality, it is possible to use the low-pass system model and thus $r(n)$ can be written as:

$$r(n) = \sum_{m=0}^{N_{FFT}-1} h(m) \left[d((n-m))_{N_{FFT}} + p((n-m))_{N_{FFT}} \right] + w(n) \quad (10)$$

where $w(n)$ is additive white Gaussian noise with zero mean and variance σ^2 . As discussed earlier, the receiver possess the knowledge that pilot carriers with null subcarriers are generated by a certain combination of positive and negative sub-pilot carriers, the Eq. (10) can be decomposed as:

$$r(n) = \sum_{m=0}^{N_{FFT}-1} h(m) \left[d((n-m))_{N_{FFT}} + p_1((n-m))_{N_{FFT}} + p_2((n-m))_{N_{FFT}} \right] + w(n) \quad (11)$$

where $n = 0, 1, \dots, N_{FFT} - 1$, $(\cdot)_{N_{FFT}}$ represents the modulo of N_{FFT} .

- Then, the cross-correlation of received sequence $r(n)$ is taken with the locally generated positive periodic sub-pilot sequence $p_1(n)$ which is defined as [13]:

$$R_{rp_1}(l) = \frac{1}{N_{FFT}} \sum_{n=0}^{N_{FFT}-1} r(n) p_1^*(n-l) \quad (12)$$

$l = 0, \pm 1, \pm 2, \dots, \pm N_{FFT} - 1$

where $1/N_{FFT}$ is the normalization factor and $(*)$ represents the conjugate operation. Therefore, using (12), we can express as [9]:

$$R_{rp_1}(l) = h(l) * [R_{dp_1}(l) + R_{p_1 p_1}(l) + R_{p_2 p_1}(l)] + R_{wp_1}(l) \quad (13)$$

It is noted that the real and imaginary components of the cross-correlation of noise $w(n)$ with $p_1(n)$, $R_{wp_1}(l)$, can be approximated as Gaussian distribution variable with zero mean and variance σ_w^2 . Also, $R_{wp_1}(l) = \tilde{w}(l)$. Then, Eq. (13) can be written as:

$$R_{rp_1}(l) = h(l) * [R_{dp_1}(l) + R_{p_1 p_1}(l) + R_{p_2 p_1}(l)] + \tilde{w}(l) \quad (14)$$

As shown in Appendix A of [11], that the cross-correlation of data $d(n)$ with positive periodic sub-pilot sequence $p_1(n)$ is zero ($R_{dp_1}(l) = 0$) over the length of cyclic prefix ($0 \leq l \leq N_p - 1$). Therefore Eq. (14) can be simplified as:

$$R_{rp_1}(l) = h(l) * [R_{p_1 p_1}(l) + R_{p_2 p_1}(l)] + \tilde{w}(l) \quad (15)$$

$0 \leq l \leq N_p - 1$

It is noted from Fig. 1 that, the energy of $p_1(n)$ and $p_2(n)$ are same. Therefore, we can rewrite Eq. (14) as:

$$R_{rp_1}(l) \cong h(l) * [2R_{p_1 p_1}(l)] + \tilde{w}(l) \quad (16)$$

It is noticeable from Eq. (16) that $R_{rp_1}(l)$ is approximately equal to the convolution of $h(l)$ and $R_{p_1 p_1}(l)$. One also written as:

$$R_{rp_1}(l) \cong 2 \sum_{n=-\infty}^{\infty} h(n) R_{p_1 p_1}(l-n) + \tilde{w}(l) \quad (17)$$

Now, we can also expressed Eq. (17) in the form of impulses:

$$h(n) = [h_0\delta(n) + h_1\delta(n-1) + \dots + h_{L-1}\delta(n - (L-1))] \quad (18)$$

$$R_{p_1 p_1}(n) = [\alpha_0\delta(n) \pm \alpha_1\delta(n \pm 1) \pm \dots \pm h_{N_F-1}\delta(n \pm N_p(N_F-1))] \quad (19)$$

where $\alpha_0, \alpha_1, \dots, \alpha_{L-1}$ are the coefficient of $R_{p_1 p_1}(n)$ and N_p is the spacing between two consecutive pair of impulses. Therefore, we can obtain $R_{p_1 p_1}(n)$ as:

$$\begin{aligned} R_{r_{p_1}}(l) \cong & 2\{[\alpha_0 h_0 \delta(n) + \dots + \alpha_{L-1} h_{L-1} \delta(n - (L-1))] + \\ & [\alpha_1 h_0 \delta(n \pm N_p) + \dots + \alpha_1 h_{L-1} \delta(n \pm N_p - (L-1))] + \\ & [\alpha_{N_F-1} h_0 \delta(n \pm N_p(N_F-1)) + \dots + \alpha_{N_F-1} h_{L-1} \delta(n \pm \\ & N_p(N_F-1) - (L-1))]\} \quad (20) \end{aligned}$$

- For catching the channel coefficients from (20), only first pair of impulses is used because high energy and low MSE values are available at this location. Hence Eq. (20) can be simplified as:

$$R'_{r_{p_1}} \cong 2[\alpha_0 h_0 \delta(n) + \dots + \alpha_{L-1} h_{L-1} \delta(n - (L-1))] \quad (21)$$

- In final step, estimated $\hat{h}(n)$ CIR is transformed into frequency domain using *FFT* operation for channel equalization.

$$\hat{H}[k] = FFT[\hat{h}(n)] \quad (22)$$

where $\hat{H}[k]$ is the estimated channel transfer function in frequency domain. To measure the performance of estimator, MSE is calculated by using the following expression:

$$MSE = E\{|H[k] - \hat{H}[k]|^2\} \quad (23)$$

where $H[k]$ is actual channel transfer function. From [14, 15], we know that the pilot-based CRB of an arbitrary estimator $\hat{H}[k]$ is

$$CRB(\hat{H}) \geq L\sigma^2 / N_p E_p \quad (24)$$

where E_p is the average power of pilot symbol and L represents the number of channel echoes used in simulation. However, it is to be noted that

$$MSE(\hat{H}) \geq CRB(\hat{H}) \quad (25)$$

Table 1. OFDM Simulation Parameters [16].

DVB-Cable Reception	
FFT Points (N_{FFT})	4096 (4K-Mode)
Carrier Spacing	2.23 kHz
Guard Interval (N_G)	1/16
Pilots Spacing (N_F)	16
Number of Pilots (N_p)	256
Signal Constellation $D[k]$	16 QAM
Pilot Constellation $P[k]$	Unipolar BPSK
FFT Sampling Frequency	9.14 MHz
Bandwidth	8 MHz
SNR Range	[-5 to 20 dB]
Channel Models	Case A, B

3. Simulation parameter

In this section, the performance of proposed algorithm is evaluated through Matlab simulation by using standard DVB-Cable reception parameters, as shown in Table 1. The performance of proposed estimator is tested in two different channel models Case (A, B), which have been chosen to verify the performance in a wide range of reception conditions [17]. The power delay profile of channel model A and B are shown in Table 2. The difference between these models is only in their delay time, channel model A has relative smaller delay time as compared to model B (worst scenario). In order to observe the channel estimation alone, a perfect synchronization is assumed. A rectangular window is implemented by using 256 null pilots in the frequency domain. For simulation, data constellation is chosen to be 16-QAM while pilot carriers are unipolar BPSK modulated and boosted with a factor of 7/3.

4. Results and analysis

This section presents the results and analysis for proposed TD-PC algorithm in the presence channel models A and B. A correlation of periodic positive pilot sub-sequence is utilized to estimate the significant taps in time domain. Fig. 3(a) investigates the cross-correlation between received signal $r(n)$ and periodic sub-pilot sequence $p_1(n)$ [$i: e R_{r_{p_1}}(l)$]. As frequency domain pilot carriers $P_1[k]$ are separated by a spacing of ($N_F = 16$), so there are ($N_F - 1$) pairs of impulses appearing on both of correlation zero lag $R_{r_{p_1}}(0)$, as shown in Fig. 3(a).

Each pair of impulses consists of 6 components for channel model; this is due to the remaining nonzero channel taps after using given sampling time. The difference between two consecutive pairs of impulses is ($N_p = 256$), because the total number of pilot used for channel estimation in each symbol is also (N_p).

Therefore, the channel co-efficient $[h_0 \ h_1 \ h_2 \ \dots \ h_{L-1}]$ appear at every (N_p) number of lags. For illustration purpose, only first of pair channel coefficient values are shown in Fig. 3(b) for channel model B at locations [0 2 6 9 17 125].

Table 2. Power delay profile for channel models A and B [18].

Path No.	Case A	Case B	Case (A,B)	
	Delay (ns)	Delay (ns)	Power (dB)	Phase (rad)
1	38	162	-11	0.95
2	181	419	-14	1.67
3	427	773	-17	0.26
4	809	1191	-23	1.20
5	1633	2067	-32	1.12
6	3708	13792	-40	0.81

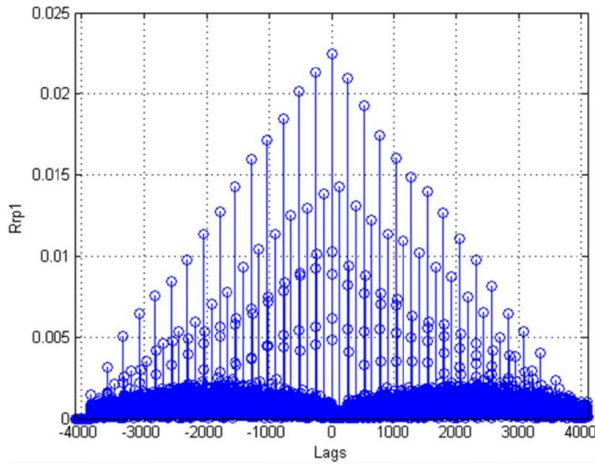

Fig. 3(a). $R_{rp_1}(l)$ Cross-correlation between received signal and positive periodic sub-pilot sequence at 10dB SNR for channel model B.

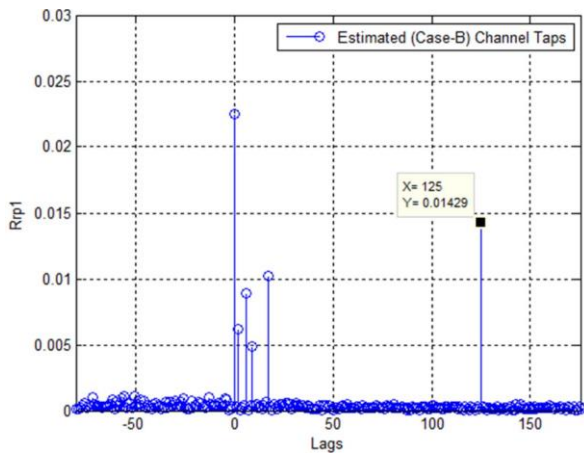

Fig. 3(b). Taps catching channel estimation at locations [0 2 6 9 17 125] for channel model B.

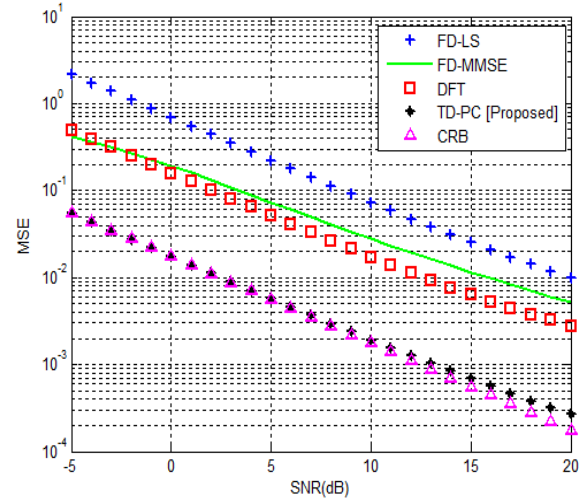

Fig. 4. Comparing MSE performance of FD-LS, FD-MMSE, DFT and proposed TD-PC estimators for channel model A.

In Fig. 4-5 MSE of four different channel estimation schemes are compared under channel model A and B respectively. In the comparison it is shown, that legends FD-LS, FD-MMSE are frequency domain and DFT, TD-PC are time domain estimators. It can be seen that MSE of proposed TD-PC algorithm over channel model A is low as compared to channel model B. The reason is that, channel model B has relatively long delay time, as shown in Table 2.

It is evident from the both figures that the performance of proposed TD-PC channel estimation is consistent and MSE is lower as compared to the conventional estimators. This is due to the zero correlation of data with positive periodic sub-pilot sequence over the length of cyclic prefix ($0 \leq l \leq N_p - 1$).

From Fig. 4, it can be seen that at SNR of 20 dB, MSE of proposed technique TD-PC is improved up to 6.8 dB, 4.1 dB and 3.6 dB with LS, MMSE and DFT methods respectively. Similarly, in Fig. 5 there is an exceptional improvement in MSE floor of proposed method. It can be further seen that in high SNR regime, the MSE of proposed method is slightly away from the CRB, which is due to the maximum delay length in Case B channel model shown in Table. 2. Hence, it can be inferred that proposed algorithm increased the performance of OFDM system by improving the estimation accuracy of CIR.

5. Complexity analysis

In this section, the computational complexity of proposed TD-PC method is evaluated, and compared with a conventional DFT-based method. For the purpose of comparison, the number of complex multiplication and addition are computed in each method.

The description of the proposed channel estimation method TD-PC in Section 2 shows that complexity load is only generated from cross-correlation term R'_{Tp_1} in Eq. (21). Since the number of channel echoes is L ; therefore $L(N_{FFT})$ number of multiplications and $L(N_{FFT} - 1)$ number of addition are required in Eq. (21).

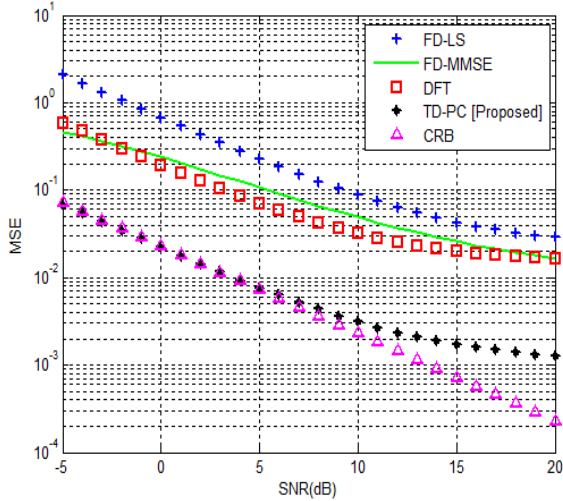

Fig. 5. Comparing MSE performance of FD-LS, FD-MMSE, DFT and proposed TD-PC estimators for channel model B.

In order to obtain a CIR through DFT method, the computational complexity comes from three parts. The first one comes from Least Squares estimation which involves the computation of N_p number of multiplications. The second one originates from the interpolation between Least Squares estimation which involves $(N_{FFT} - N_p)$ number of complex multiplication and $2(N_{FFT} - N_p)$ complex additions. The third one comes from DFT and IDFT operations which includes the $(N_{FFT} \log_2 N_{FFT})$ number of complex multiplication and $2(N_{FFT} \log_2 N_{FFT})$ complex additions.

The complexity of TD-PC and DFT estimators discussed above is summarized in Table 3. It can be seen from Table 3 that proposed TD-PC estimator enjoys a lower complexity than the DFT-based method. Moreover, proposed TD-PC method will lead to more significant reduction in complexity when the dimension of L becomes larger. Therefore, proposed scheme optimizes the system performance by obtaining the low computational complexity.

Table 3. Complexity comparison of proposed TD-PC and DFT-based estimators ($N_{FFT} = 4096, L = 6, N_p = 256$).

Estimator	Complex Multiplication	Complex Addition
TD-PC	$(L)N_{FFT}$	$L(N_{FFT} - 1)$
DFT	$(1 + \log_2 N_{FFT})N_{FFT}$	$2N_{FFT} + (\log_2 N_{FFT}) - 2N_p$

6. Conclusion

This paper presents improved time domain OFDM channel estimation for DVB-Cable receivers. In this paper, receiver assumes that the pilots with null subcarriers are generated by a certain combination of positive and negative sub-pilots tones. The impulse response of the channel is obtained by exploiting a cross-correlation approach between received signal and positive periodic sub-pilot sequence. This approach gives an advantage in terms of low MSE floor. Simulation results suggest that the proposed algorithm achieves a better accuracy as compared to conventional frequency and time domain estimators. Moreover, the computational complexity of proposed method is reduced by exploiting the correlation between data and positive periodic sub-pilot sequence.

Acknowledgment

The authors would like to thank Universiti Teknologi PETRONAS (UTP) in particularly Centre of Graduate Studies (CGS) in providing research fund for this study.

References

- [1] A. A. Quadeer, M. S. Sohail, IEEE International Symposium on Signal Processing and Information Technology, 277 (2010).
- [2] Y. Honqwei, Communications Magazine IEEE. **43**, 53-60 (2005).
- [3] Peng, Mingli, Zhuo Sun, Wenbo Wang, IET International Conference IET, 187 (2011).
- [4] Y.-S. Lee, H.-N. Kim, K. S. Son, Consumer Electronics, IEEE Transactions on. **53**, 27-32,(2007).
- [5] V. Savaux, Y. Louët, M. Djoko-Kouam, A. Skrzypczak, IET Communication. **49**,18,1152 (2013).
- [6] D. V. F. Lopez.: 'Two-steps least squares time domain channel estimation for ofdm systems', US 20100195774 **A1**, (2010).
- [7] S. Manzoor, V. Jeoti, N. Kamel, M. A. Khan, International Journal of Future Generation Communication and Networking. **4**, 1 (2011).
- [8] A. Ijaz, A.B. Awoseyila, B.G. Evans, IET Communication, **47**(20), 1154 (2011).
- [9] Xianbin, W. Yiyan Wu, Jean-Yves Chouinard, Sili Lu, Bernard Caron, Consumer Electronics, IEEE Transactions on. **49**(4), 949 (2003).
- [10] K. Y. Lin, H. J. Huang, H. P. Lin, S. S. Jeng, In Broadband Multimedia Systems and Broadcasting, IEEE International Symposium on, 1 (2008).
- [11] L. Mingqi, T. Jianguo, Z. Wenjun, Consumer Electronics, IEEE Transactions on. **50**(4), 1049 (2004).
- [12] A. M. Khan, V. Jeoti, M. A. Zakariya, in Wireless Technology and Applications (ISWTA), IEEE Symposium on, 120 (2013).

- [13] J. G. Prokakis, Digital Signal Processing, McGraw-Hill, 4th edn. (2004).
- [14] S. M. Kay, Fundamentals of Statistical Signal Processing, Volume II: Detection Theory, Prentice Hall, (1998).
- [15] Yuan Wang, Zhongpei Zhand, Yixian Chen, TELKOMNIKA Indonesian Journal of Electrical Engineering, **12** (9), 6860-6867, (2014).
- [16] Fisher, W, Digital Video and Audio Broadcasting. A Practical Engineering Guide, Springer, 2nd ed, (2010).
- [17] DVB-C2, "Digital cable transmission system," Document A147, (2013).
- [18] Jiyan Huang, Peng Wang, Xiaofeng Shen, Radioengineering, 21, 1117-1124, (2012).

*Corresponding author: abid.mk_g01917@utp.edu.my