

Magneto-optical effects in nematic liquid crystal doped with Prussian Blue

C. ROȘU^a, C. CARTOAJE^a, A. L. PĂUN^b

^aFaculty of Applied Sciences, University “Politehnica” Bucharest, Splaiul Independentei 313, Bucharest, 060032, Romania

^bAgricultural Highschool, Roșiorii de Vede, Romania

The effects induced by the magnetic field into a mixture of a nematic liquid crystal with a small amount (0.5% by wt.) of ferromagnetic compound (Prussian Blue) were investigated. The optical effects were examined using Faraday configuration (i.e. magnetic field parallel to the incident light). We have measured the transmitted light intensity (He-Ne, $\lambda=632.8$ nm) through the sample when subjecting it to an increasing magnetic field. We have also performed measurements on the liquid crystal mixture rotatory power, for different magnetic field values. We found that the ferromagnetic dopant induces optical activity into the nematic sample. When the mixture was subjected to an increasing magnetic field, the emerging light was found to be elliptically polarized, the ellipticity depending on magnetic field strength. The light transmission, the rotatory power and the ellipticity varied quasiperiodically at high magnetic field strengths. The observed phenomena may be explained if we consider that the rotatory polarization arises as a result of disturbing the nematic order by the ferromagnetic particles.

(Received March 28, 2008; accepted February 13, 2009)

Keywords: Nematic liquid crystal, ferromagnetic compound, light transmission, rotatory power, ellipticity.

1. Introduction

The research concerning the phenomena which appear in liquid crystals (LCs) doped with ferromagnetic particles have begun in 1970 with the work of Brochard and de Gennes [1]. They pointed out that if the colloidal ferromagnetic particles have permanent magnetic moments, the orientation of their local moments and the nematic director would be coupled giving rise to new and useful effects. These mixtures are termed ferronematics. In 1983, Chen and Amer produced the first ferromagnetic suspension based on ferromagnetic particles of ferric oxide in a LC matrix [2]. Further works, both theoretical [3], [4] and experimental [5], [6] improved the picture predicted by Brochard and de Gennes.

In the last two decades interest in ferronematics has grown as they promise to provide an optical device technology based on magnetic switching [7]-[10].

On the other side, Prussian Blue has been extensively studied due to its unusual properties: it undergoes intervalence charge transfer, it is electrochromic (changing colour from blue to white in response to a voltage), it undergoes spin-crossover behaviour making this material one of the fewest known classes of substances that have a magnetic response to the light.

In this paper we investigate some magneto-optical effects of a colloidal suspension of Prussian Blue into a nematic liquid crystal matrix, when subjecting it to laser irradiation. The studies were performed with the magnetic

field applied along the propagation direction of the optical beam (the polar case of the Faraday configuration). The laser beam falls at normal incidence on the liquid crystal cell.

The article is organized as follows: First, the experimental materials and set-up are described. Second, experimental results referring to magnetic field effects on light transmission, induced rotatory power and ellipticity are presented and discussed.

2. Experimental

Liquid crystal cells, with Mylar spacers of 50 μ m thickness, were filled by capillarity with the nematic liquid crystal compound MLC-6601 (Merck) doped with small amounts (0.5% by wt.) of the ferromagnetic compound Prussian Blue. The nematic host has the clearing point at 77°C and the refractive indices $n_e=1.5498$, $n_o=1.4735$, $\Delta n=0.0763$ (determined for $\lambda=589.3$ nm, at 20°C). Before filling the symmetric cell with the Prussian Blue – nematic mixture (NPB), its glass substrates were coated with polyvinyl alcohol surfactant and were unidirectionally rubbed, in order to obtain a planar alignment of the liquid crystal molecules (the long molecular axis parallel with respect to the glass substrates).

The experimental set-up is shown in Fig. 1. The LC cell was placed in the middle of the electromagnet (E) provided with hollow poles. The He-Ne laser beam

(632.8nm, 1mW) falls at normal incidence on the cell's glass plates. Thus, in this configuration (named Faraday configuration) the magnetic field is parallel to the incident light. At the exit, the plane of polarization was determined by rotating a Glan-Thomson polarizer (P) to obtain the extinction of the transmitted light. The intensity of the transmitted light was recorded by means of a

photomultiplier (Ph), connected at a multimeter (M). Changes in the magnetic field strength were achieved by a DC power supply (PS) which allowed both current adjustment and change of polarity. The experimental procedure was similar with that described in [11].

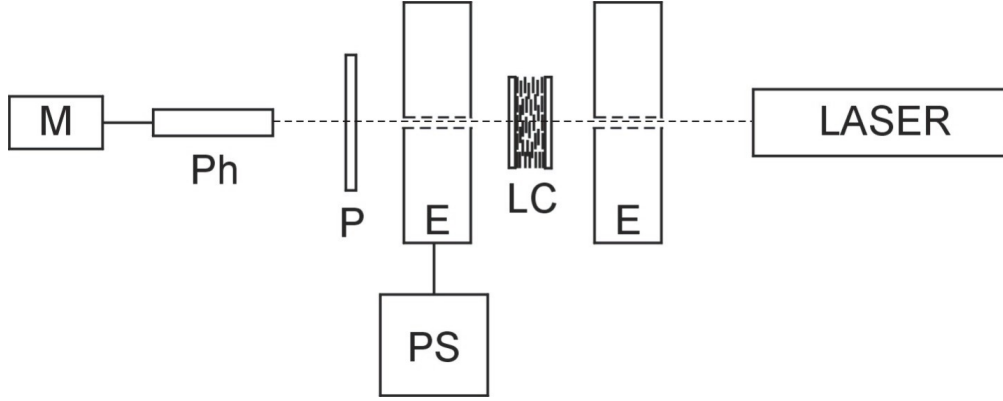

Fig. 1. Experimental set-up.

3. Results and discussion

The critical magnetic field for the Freedericksz transition in planar aligned cells filled with a ferromagnetic substance was found to be [3]

$$B_c^2 = \frac{\mu_0 K_1}{\chi_a} \left(\frac{\pi}{d} \right)^2 + \frac{2\mu_0 fW}{a\chi_a}, \quad (1)$$

where d is the LC cell thickness, K_1 the splay elastic constant, $\chi_a = \chi_{\parallel} - \chi_{\perp}$ the anisotropy of the pure LC magnetic susceptibility, $\mu_0 = 4\pi \times 10^{-7} \text{ N/A}^2$ the magnetic permeability of free space, W the surface density of the nematic anchoring energy, f is the volume fraction of magnetic particles assumed to be a cylinder with diameter with a .

When the LC cell is subjected to magnetic fields higher than B_c , the light transmission varies quasiperiodically. The results are shown in Fig. 2, for the planar oriented LC cell. The oscillations of the transmitted light are due to the interference of extraordinary and ordinary rays passing through a birefringent slab.

If we consider the light propagating along the Oz axis, the optical path difference between the ordinary and extraordinary rays is

$$l = \int_{-\frac{d}{2}}^{\frac{d}{2}} (n_{ef} - n_o) dz, \quad (2)$$

where n_o is the ordinary refractive index and n_{ef} is the effective refractive index. For the planar aligned cell, n_{ef} is given by

$$\frac{1}{n_{ef}} = \frac{\cos^2 \alpha}{n_o^2} + \frac{\sin^2 \alpha}{n_e^2}, \quad (3)$$

where n_e is the extraordinary refractive index and $\alpha = \frac{\pi}{2} - \theta$, where θ is the LC director distortion angle of nematic director.

The free energy density of a planar oriented ferronematic is given by:

$$f = f_N + f_M - \frac{1}{2} \gamma \frac{\partial \theta}{\partial t} \quad (4)$$

Where

$$f_N = \frac{1}{2} (K_1 \cos^2 \theta + K_3 \sin^2 \theta) \theta_z^2 - \mu_0^{-1} \chi_a B^2 \sin^2 \theta \quad (5)$$

is the free energy density of a planar oriented nematic subjected to a magnetic field [12,13] and $\theta_z = \frac{\partial \theta(z)}{\partial z}$. In

Eq. 5 K_1 and K_2 are the splay and bend elastic constants,

respectively, and θ the deviation angle of the nematic director.

$$f_M = -M_s f(\vec{m}\vec{B}) + \frac{fk_B T}{V} \ln f + \frac{fW}{a} (\vec{n}\vec{m})^2 \quad (6)$$

is the contribution of the magnetic particles to the free energy density. In Eq. 6 M_s is the saturation magnetisation, \vec{m} the magnetic moment and V the volume of the particle, respectively.

The last term intervening in Eq. 3 corresponds to viscous torques and is important when dynamical problems are involved. $\theta = \theta_m \cos \frac{\pi z}{d}$ where θ_m is the maximum distortion angle in the middle of the liquid crystal cell. When small deviation angles are involved ($\theta \ll 1$) the path difference of the transmitted light is given by $l = \Delta n \frac{d}{2} \theta_m^2$, where $\Delta n = n_e - n_o$ is the birefringence of the liquid crystal cell. The phase difference between the ordinary and extraordinary rays is

$$\delta(B) = \frac{2\pi d}{\lambda} \Delta n(B) - \frac{\pi d \theta_m^2}{\lambda} \Delta n(B) \quad (7)$$

In case of higher distortion $l = \Delta n \frac{d}{2} \left(\theta_m^2 - \frac{\theta_m^4}{4} \right)$ [14] and the phase difference is

$$\delta(B) = \frac{2\pi d}{\lambda} \Delta n(B) - \frac{\pi d}{\lambda} \Delta n(B) \left[\theta_m^2 - \frac{1}{4} \theta_m^4 \right], \quad (8)$$

The transmitted light intensity through the ferronematic sample is given by [14]

$$I = I_0 \sin^2 [2\Phi(B)] \sin^2 \frac{\delta(B)}{2}, \quad (9)$$

where $\Phi(B)$ is the angle between the molecular director and the direction of incident light polarization. In our experiment, this angle depends quasiperiodically on the magnetic field strength.

From Eq. (9) it is obvious that the transmitted light intensity will pass through a sequence of minima and maxima when increasing the magnetic field above the critical field for Freedericksz transition (Eq. 1). This behaviour results from the magnetic field dependence of both rotation angle and phase retardation. As a

consequence, the shape of the transmitted light intensity oscillations (Fig. 2) is quite different when compared to that recorded with fixed cross polarizers [12, 13].

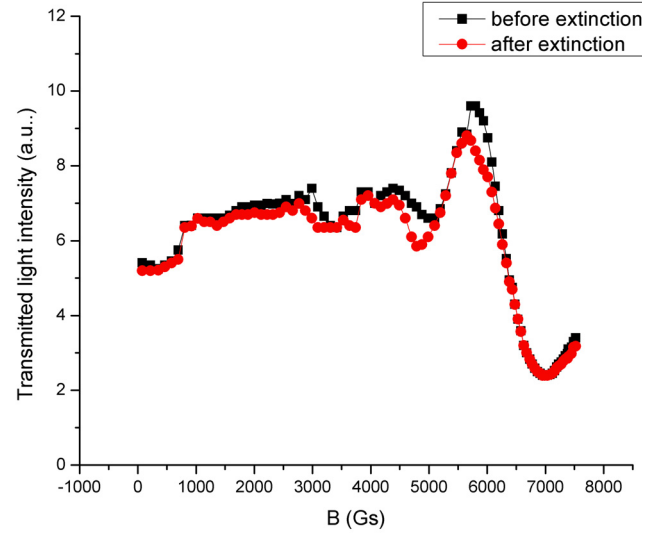

Fig. 2. Light transmission versus magnetic field strength, before and after rotating the polarizer for total extinction.

We have also performed measurements concerning the rotatory power of the NPB colloidal suspension. We found that at zero magnetic fields, the NPB cell displayed a very low rotatory power (2°), which may be ascribed to the asymmetry induced by the ferromagnetic molecules suspended in the nematic host [16]. When increasing the magnetic field, the rotation angle varies quasiperiodically as shown in Fig. 3. A quite similar behaviour was noticed in azo-dye doped nematic liquid crystals, where the optical activity was induced by the cis isomer of the azo compound [11], [17]. For the NPB mixture, the rotation angle oscillations when varying the magnetic field could be a consequence of the interference between the right and left circular polarized components of the linear polarized light passing through the sample [18 and the references therein]. Unlike the previously reported results referring the Faraday rotation angle reported in the same experimental configuration for the azo-dye doped nematic liquid crystal [19], for the NPB mixture the average rotation angle as function of the magnetic field strength has a more complicated behaviour. No linear dependence on the magnetic field of the Faraday rotation angle was noticed in this case.

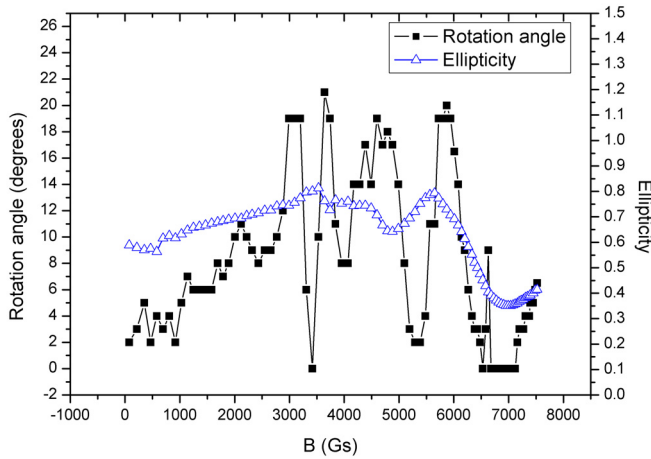

Fig. 3. Rotation angle and ellipticity as functions of the magnetic field strength, for the LC cell with planar alignment and $50\mu\text{m}$ thickness.

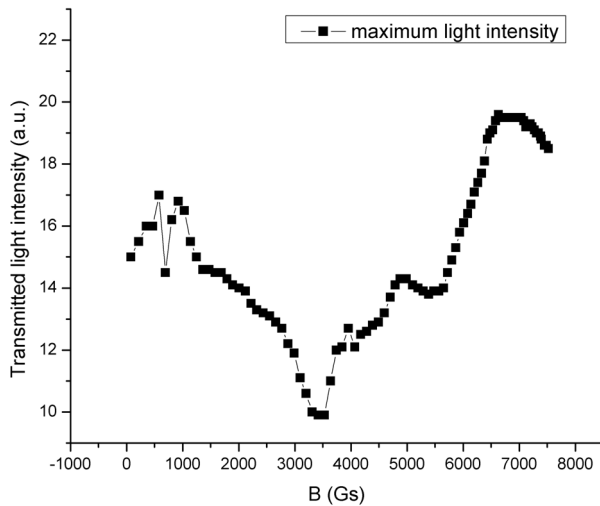

Fig. 4. The maximum intensity of the transmitted light as a function of the magnetic field.

Another result of doping the liquid crystal with ferromagnetic particles is that the linear polarized light of the He-Ne laser beam, passing through the sample, becomes elliptically polarized (Fig. 3). The ellipticity, $\varepsilon = \sqrt{B/A}$, (where B and A are the half-axes of the ellipse), may be determined from the experimental data [20], using the formula

$$\varepsilon = \sqrt{\frac{I_{\min}}{I_{\max}}}, \quad (5)$$

where I_{\min} is the light intensity measured after the polarizer was rotated up to the maximum extinction of the

transmitted light and I_{\max} is the maximum intensity of the transmitted light (Fig. 4).

If the analyzer is eliminated, the NPB cell behaves as a retardation plate. Using the same method as that reported in [18], we determined the magnetic field values where the NPB cell acts as a wave (λ) and as a half-wave ($\lambda/2$) retardation plate. The results are summarized in Table 1.

Table 1. Liquid crystal phase retardation plate characteristics.

| B (Gs) | NPB $50\mu\text{m}$ |
|--------|---------------------|
| 3740 | $\lambda/2$ |
| 3995 | λ |
| 4790 | $\lambda/2$ |
| 6910 | λ |

5. Conclusions

A new ferronematic (Prussian Blue embedded into a nematic liquid crystal) was investigated when subjecting it to a magnetic field. We found that the mixtures displayed optical activity with a rather high rotary power. The linear polarised He-Ne laser beam passing through the liquid crystal cell was converted into an elliptically polarised one. This make possible the cell to be used as a wave (λ) or half-wave ($\lambda/2$) retardation plate when applying different magnetic field strengths.

Acknowledgements

The authors acknowledge the Romanian Ministry of Education and Research for financial support under the CEEEX program, Project CEX-05-D11-76.

References

- [1] F. Brochard, P. G. de Gennes, *J. Phys. (Paris)*, **31**, 691 (1970).
- [2] S. H. Chen, N. M. Amer, *Phys. Rev. Lett.* **51**, 2298 (1983).
- [3] S. V. Burylov, Yu. L. Raikhler, *Mol. Cryst. Liq. Cryst.*, **258**, 107 (1995).
- [4] A. N. Zakhlevnykh, *J. Magn. Magn. Mater.* **269**, 238 (2004).
- [5] B. J. Liang, S. H. Chen, *Phys. Rev. A*, **39**, 1441, (1989).
- [6] V. I. Zadorozhnyi, A. N. Vasiliev, V. Y. Reshetnyak, K. S. Thomas, T. J. Sluckin, *Europhys. Lett.*, **73**(3), 408 (2006).
- [7] Yu. L. Raikhler, V. I. Stepanov, *J. Magn. Magn. Mater.*, **201**, 182 (1999).

- [8] I. Potocova, et al., *J. Magn. Magn. Mater.* **201**, 163 (1999).
- [9] C. Y. Matuo, A. M. Figueiredo Neto, *Phys. Rev. E* **60**, 1815 (1999).
- [10] S. K. Srivatsa, G. S. Ranganath, *Phys. Rev. E* **60**, 5639, (1999).
- [11] C. Moțoc, G. Iacobescu, *Mod. Phys. Lett. B* **20**(17), 1015 (2006).
- [12] C. Moțoc, E. Petrescu, *Mod. Phys. Lett. B* **12**(13), 529 (1998).
- [13] C. Moțoc, E. Petrescu, C. Dascălu, *SPIE*, Vol. **3405**, 941 (1998).
- [14] E. Petrescu, C. Moțoc, *Mod. Phys. Lett. B*, **14**(4), 139 (2000).
- [15] M. Born, E. Wolf, in “Principles of Optics”, Pergamon Press, London, (1965).
- [16] G. Bruhat, in “Optique”, Masson & Cie, Paris, p. 552 (1947).
- [17] C. Moțoc, G. Iacobescu, *J. Magn. Magn. Mater.*, **306/1**, 103, (2006).
- [18] C. Moțoc, G. Iacobescu, *JOAM*, **8**(1), 295, (2006).
- [19] C. Moțoc, G. Iacobescu, *JOAM*, **7**(6), 3111, (2005).
- [20] D. O. Krimer, L. Kramer, E. Brasselet, T. V. Galstyan, L. J. Dubé, *JOSA B*, **22**(8), 1681, (2005).

*Corresponding author: rosudanut@gmail.com