

Fiber Bragg gratings written in photosensitive photonic crystal fibers and its sensing applications

I. R. IVASCU^a, R. GUMENYUK^b, S. KIVISTÖ^b, A. N. DENISOV^c, A. F. KOSOLAPOV^c, Y. P. YATSENKO^c,
S. L. SEMJONOV^c, O. G. OKHOTNIKOV^b

^aUniversity "Politehnica" of Bucharest, Physics Department, 313 Splaiul Independentei, Bucharest, 060042, Romania

^bOptoelectronics Research Centre, Tampere University of Technology, P.O. Box 692, FIN-33101 Tampere, Finland

^cFiber Optics Research Center, Russian Academy of Sciences, 38 Vavilov Street, Moscow, 119333, Russia

In this paper we report on strong fiber Bragg gratings (FBGs) with reflectivity over 84%, photo-written in a novel photosensitive photonic crystal fiber (PCF) using a conventional phase-mask technique and 248 nm KrF excimer laser. Two types of highly Ge-doped core PCFs having different structures were employed in experiments. The high photosensitivity of fiber allowed us to achieve strong FBGs without hydrogen loading thus avoiding the inconveniences related to loaded fibers splicing, possible decrease of the grating reflectivity due to annealing and power losses. A significant effect of the PCF structure on the Bragg resonance wavelength of the FBG was observed. In addition to the core Bragg resonance, the secondary resonances have been displayed. The temperature and strain sensitivity of the FBG in PCF has been derived and compared it with a standard single mode fiber. The FBG photo-imprinted in PCF could be used as temperature, strain and chemical sensors.

(Received June 20, 2011; accepted July 25, 2011)

Keywords: Photonic crystal fiber, Fiber Bragg grating, Bragg wavelength, Phase mask technique, Temperature and strain sensor

1. Introduction

Since the first demonstration of the photonic crystal fiber (PCF) in 1996 [1], it has become an interesting and extensively developed subject in the worldwide optical field research, leading to a large variety of its designs and applications [2, 3]. The PCFs known as microstructured fibers also, are distinguished from standard "step-index" optical fibers by their cladding formed by low refractive index inclusions, such as air holes, that run along to the entire fiber core length. In the case of PCF having a solid core, due to the presence of the air holes, the microstructured cladding has the effective refractive index lower than that of the core thus guiding the light through the core by total internal reflection principle. This type of fiber was named index-guiding PCF [4]. The PCF fiber core could be also empty, formed by a hollow air surrounded into the center of a microstructured cladding. In this case, the cladding plays the role of a 2D loss-free mirror, guiding into the core, the strong resonance wavelengths reflected by the cladding microstructure at certain angles and wavelengths. These fibers were called photonic bandgap fibers (PBGF) [5].

The unique properties of PCFs have created many opportunities for controlling the transmission properties of guided modes by creating PCF with an appropriate holes microstructure design to the purposed scope. By tailoring the geometrical parameters of PCFs such as the air holes diameter, the distance between them or filling the air holes with a liquid, it is possible to fabricate fibers with extended range of cutoff wavelength, dispersion, mode

field diameter and bandwidth of the transmitted spectrum [6, 7]. Furthermore, these characteristics of PCF would allow for new properties of fiber Bragg gratings (FBGs) written in PCF as compared with those written in standard fiber [8].

A common method to write FBG into a standard fiber core is the phase mask technique which consists in exposing the fiber core to an UV laser beam interference pattern coming from a phase mask placed within approximately few micrometers distance to the fiber. Under the influence of UV light pattern, the core refractive index is modulated and resulting a FBG [9]. The silica fiber core is usually doped with a photosensitive material (e.g. germanium, phosphorous [6], or germanium-boron codoping [10]) in order to increase its photosensitivity. Further, it can be additionally photo-sensitized by loading it with hydrogen prior to UV exposure. However, the presence of hydrogen in the fiber core is always related with a significant loss in signal transmission. Hence, annealing operation of the FBG written in a loaded fiber compulsory succeeds the photo-imprinting stage, for hydrogen out-diffusion purpose. Both hydrogenation and annealing processes take long time and introduce some inconveniences related to the splicing of the loaded fibers, possible attenuation of the grating reflectivity due to annealing and power losses, therefore they are better to be avoided. However, writing the FBG into a PCF core using the phase mask technique, as it was described before, it raises a series of additional problems respect to standard fiber. Firstly, the cladding microstructure adds extra scattering which alters the UV fringe pattern of the phase

mask structure, making the photo-imprinting process of the FBG in PCF less efficient than in standard fiber. Secondly, improving the PCF photosensitivity by hydrogen loading imposes some experimental restrictions coming from the rapid hydrogen out diffusion due to the proximity of the air holes along the fiber core. An amount of 95% of the molecular H_2 initially existent in fiber diffuses out in a few minutes, (8 min – at the room temperature) [11] which is less than is typically necessary to manage and complete FBG writing. The solution to overcome these issues consists in writing FBG in hydrogen loaded PCF spliced to its both end facets with short pieces of standard fibers before hydrogenation stage. However, this is still an inconvenient solution because this operation requires extra time and it has the multiple typical disadvantages of the loaded fibers. Even its fabrication is a challenge task for any researcher, difficulties coming from experimental constrains, the Bragg grating directly photo-imprinted in PCF is very desirable, in order to use the presence of air holes around the core, which can be filled or not with a liquid [12, 13], gas [14] or biofilm [15] in sensor applications [4].

In this paper we report on strong uniform FBGs, photo-written in a novel photosensitive PCF using a conventional phase-mask technique and 248 nm KrF excimer laser, without hydrogen loading. We have studied two types of highly Ge-doped core PCFs having different structures. The high photosensitivity of fiber allowed us to achieve strong FBGs, with the reflectivity over 84%, avoiding the inconveniences related to loaded fibers. It was observed that the PCF structure has a significant effect on the Bragg resonance wavelength of the FBG. In addition to the fundamental Bragg resonance, the secondary resonances have been displayed. All gratings imprinted in these fibers were rigorously tested. Particularly, the temperature and strain sensitivity of the FBG in PCF have been derived and compared with those written in a standard single mode fiber. The FBG photo-imprinted in PCF could be used in variety of sensing applications such as temperature, strain and chemical sensors.

The paper is organized as follows: in Sect. 2 we present the experimental conditions including materials used and experimental setup. In Sect. 3 we show the relevant results and in Sect. 4 we draw the conclusions of this work.

2. Experimental conditions

2.1. Materials

A. Standard fiber

In this work OFS single-mode fiber was used with the following main properties: core diameter of 4.4 μm , and numerical aperture of 0.16. The OFS fiber was highly hydrogen loaded prior inscription by placing it into a pressure controlled hydrogen chamber for at least 7 days, under pressure of 130 atm and room temperature.

B. Photonic crystal fibers

Two types of highly Ge-doped core PCFs having different structures (labelled as PCF #1, PCF #2) were employed in experiment. They were supplied by the Fiber Optics Research Center of the Russian Academy of Sciences from Moscow, Russia. The cross sections of the PCFs used in the work are shown in Fig. 1(a) and (b). As it is observed, the microstructures of the both PCFs are formed by two air-hole rings with a hexagonal configuration, disposed around the core. The difference in the two microstructures is made by the values of the diameter of the air-holes and interhole spacing, which vary between the rings and the PCFs.

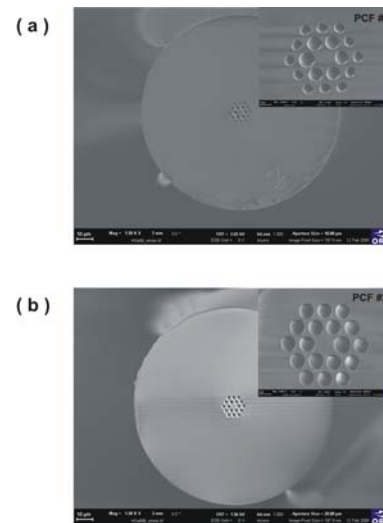

Fig. 1. Cross sectional SEM images of the PCFs structures; (a) PCF #1 and (b) PCF #2.

The measurements made by scanning electron microscope (SEM) show that the core diameters are approximately 4 μm (PCF #1) and 3.6 μm (PCF #2) with the photosensitive region of 1.9 μm for the both fibers. In the case of PCF #1, the air holes which form the inner ring have the diameter value in the range of 2.51–3.06 μm with approximately of 750 nm distance between them; the exterior ring is formed by air holes with the diameter of approximately 1.8 μm having the interhole spacing around of 1 μm . The microstructure of the PCF #2 is rather uniform, with the air holes diameter approximately of 2.5 μm and the period closed to 500 nm, for both holes rings.

2.1. Set-up for writing FBGs

All gratings were written using phase-mask technique. The photo-printed process was carried out using a 248 nm KrF excimer laser with a repetition rate of 30 Hz, an exposure time in the range of 40 s – 2 min, and the beam energy between 20 mJ – 26 mJ. The highest values in both energy and time were used during the photo-imprinting process of the PCFs. The phase-mask supplied by Stocker

Yale had the uniform period of 714.99 nm and the length of 1 cm for all gratings. The FBGs were interrogated by a broadband spectrum of an Yb-doped fiber ASE source, while the Bragg resonance wavelengths have been displayed and measured using an optical spectrum analyzer (OSA) – ANDO AQ6317B, with the resolution of 0.01 nm.

Each piece of PCF in which we have written the FBG was spliced with OFS single mode fiber to both ends in order to connect it to the interrogation light source and to the OSA. The fusion splicing was carried out by using a commercial splicing machine (Ericsson FSU 995 FA Fusion Splicer). For an optimal fusion splicing, the optical power of the laser source was launched into the fiber and collected at the output end with a powermeter. When the output signal was at maximum through optimization of the fibers alignment (between OFS and PCF), the fusion splice was completed [6].

After the photo-imprinting process, the reference OFS fiber containing FBG was annealed by leaving it into an oven for 48 hours at 60 °C for hydrogen out-diffusion.

2.2. Characterization of the FBGs on strain and temperature sensitivity

The most tempting way to characterize an FBG for sensing purpose is basically related with its well known sensitivity on strain and temperature. Further, by covering standard fiber [16] or filling with different substances the air holes of the PCF within grating area, the FBG becomes a very useful tool for many other sensing applications such as: gas sensor, refractive index sensor, bio-sensor [4, 15]. Hence, it is very interesting to determine and compare the specific sensitivity of the FBG written in PCF with that of the FBG written in standard fiber.

The characterization of the strain sensitivity of the FBGs was carried out by applying longitudinal tension to the grating using a fiber handling device and a computer control (Fig. 2). The tension range was varied from 0 N to 5 N. The tension values under the FBG were rigorously set each time by a dedicated LabView program.

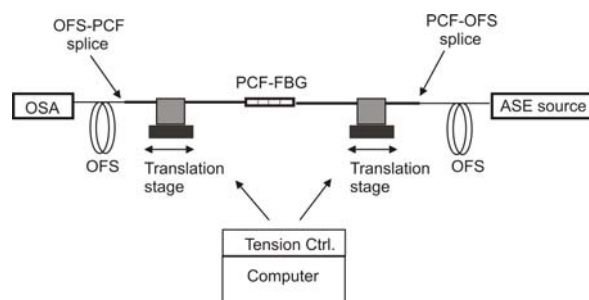

Fig. 2. Set-up for characterization on strain of the FBG written in PCF.

The temperature measurements were made using an oven with a temperature accuracy of 0.1 °C as it is schematically shown in Fig. 3. The temperature range was varied from 25 °C to 195 °C.

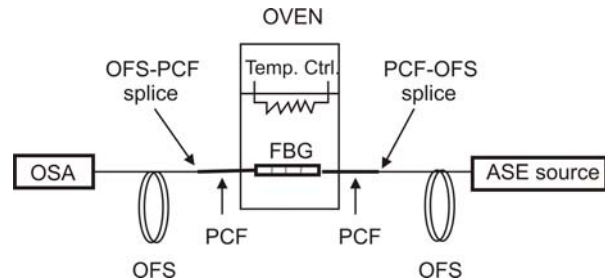

Fig. 3. Set-up for characterization on temperature of the FBG written in PCF.

3. Results and discussions

The measured FBG spectra corresponding to both types of PCFs are shown in Fig. 4 (PCF #1) and Fig. 5 (PCF #2), respectively. Regarding these spectra, it is observed that the PCF structure has a strong effect on the Bragg resonance wavelength of the FBG. The FBGs written in the two types of PCFs reflect the light corresponding to the core Bragg resonances at different wavelengths, even the photo-imprinting process was carried out using the same phase mask in the both cases. Moreover, for the FBG written in PCF #2, in addition to the core Bragg resonance, the secondary resonances have been observed (Fig. 5). The measured reflectivity of the core Bragg resonances was of 84% (PCF#1) and it reached 85% (PCF#2).

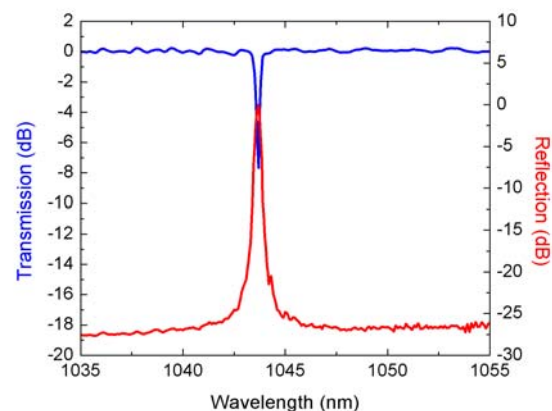

Fig. 4. The transmitted and reflected spectra of the FBG written in PCF #1.

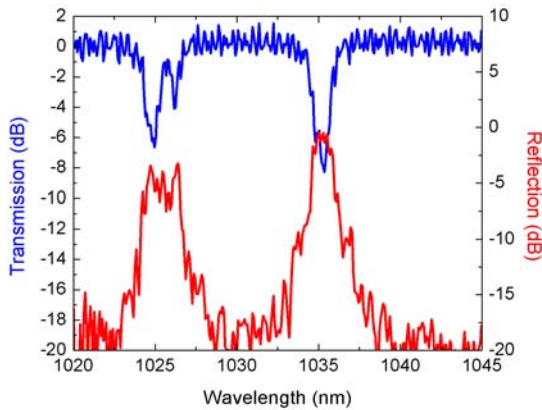

Fig. 5. The transmitted and reflected spectra of the FBG written in PCF #2.

The measured FBG spectra corresponding to the FBG photo-imprinted in the OFS fiber are presented in Fig. 6. The corresponding Bragg wavelength was measured to be around 1039.6 nm with a reflectivity of 87%.

Even if the FBGs writing in both fiber types (OFS and PCFs) was carried out using the same phase mask, a significant difference between their fundamental Bragg wavelength values is observed. This is mainly due to different core effective refractive indices of the different fibers. In addition the air holes microstructure of the PCF might alter the UV interference pattern of the phase mask during the photo-inscription process.

Thanks to the high photosensitivity of the PCFs we obtained strong FBGs in PCFs without hydrogen loading. Their reflectivity values are comparable with that of the FBG written in hydrogen loaded OFS fiber.

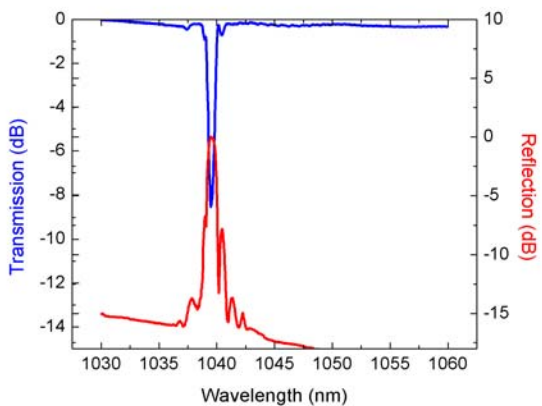

Fig. 6. The transmitted and reflected spectra of the FBG written in OFS fiber.

The wavelength shifts of the fundamental Bragg resonances for the applied tension are presented for the PCFs in Fig. 7. The measured strain sensitivity coefficients corresponding to the core Bragg resonances were of 1.00

nm/N (PCF#1), and 0.94 nm/N (PCF#2). There is not a significant difference between the values, that could be explained by the fact that the light is guided mainly within the solid core by index-guiding principle and not through to the microstructured cladding. However, the inner air holes microstructures of the two types of PCF we have studied were not dramatically different.

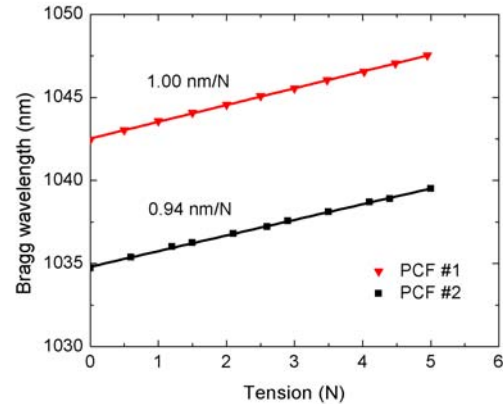

Fig. 7. Dependence of the fundamental Bragg wavelength on applied tension for FBGs in both PCFs.

Fig. 8 presents the wavelength shifts of the fundamental Bragg resonances for the applied temperature for FBGs written in PCFs. The measured temperature sensitivity coefficients corresponding to the core Bragg resonances were of 6.3 pm/°C (PCF #1), and 5.3 pm/°C (PCF #2). It is observed that there is a weak difference between them; the FBG written in PCF #2 is less sensitive in temperature change than the FBG written in PCF #1. From this point of view, the air-holes rings surrounding the fiber core have a thermal isolator role for the core. According to the microstructure design of the two PCFs displayed in Fig. 1 (a) and (b), it can be seen that the air-holes diameters of PCF #2 are slightly bigger than those of PCF #1, hence the less sensitivity in temperature of the PCF #2 respect to the other one (PCF #1).

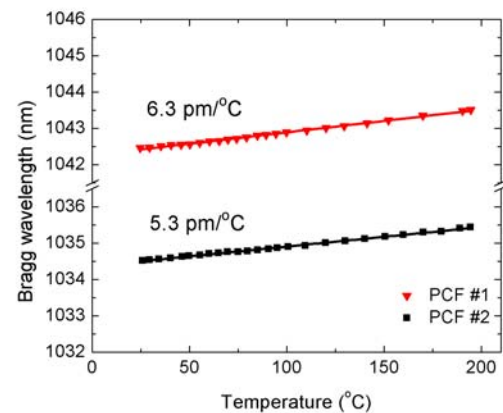

Fig. 8. Dependence of the fundamental Bragg wavelength on temperature for FBGs in both PCFs.

We have investigated the FBG photo-imprinted in the OFS fiber, also. The corresponding strain and temperature coefficients of the FBG written in OFS fiber were measured to be 0.99 nm/N and 6.08 pm/°C respectively.

4. Conclusions

Strong FBGs in Ge-doped PCF having the reflectivity over 84% were fabricated by phase mask technique, without hydrogen loading indicating their high photosensitivity. The PCF air-holes microstructure has a significant effect on the Bragg resonance wavelength. The sensitivity level in temperature and strain of the FBG written in PCF are comparative with those written in OFS, because in the both cases (PCF and OFS fibers) light is guided through the solid core. The FBGs photo-imprinted in PCF could be used for a large variety of temperature, strain and chemical sensors.

Acknowledgement

Many thanks go to the Centre for International Mobility of Finland, CIMO for a research stage fellowship support at the Ultrafast and Intense Optics Laboratory within the Optoelectronics Research Centre of the Tampere University of Technology, from Tampere, Finland, under the supervision of Prof. Oleg Okhotnikov, PhD.

References

- [1] J. C. Knight, T. A. Birks, P. St. J. Russell, D. M. Atkin, *Opt. Lett.*, **21**, 1547 (1996).
- [2] B. J. Eggleton, P. S. Westbrook, R. S. Windeler, S. Spalter, T. A. Strasser, *Opt. Lett.*, **24**, 1460 (1999).
- [3] P. Russel, "Photonic-Crystal Fibers", *J. Lightw. Technol.*, **24**, 4729 (2006).
- [4] O. Frazão, J. L. Santos, F. M. Araújo, L. A. Ferreira, *Laser & Photon. Rev.*, **2**, 449 (2008).
- [5] R. F. Cregan, B. J. Mangan, J. C. Knight, T. A. Birks, P. St. J. Russell, P. J. Roberts, D. C. Allan, *Science*, **285**, 1537 (1999).
- [6] V. Beugin, L. Bigot, P. Niay, M. Lancry, Y. Quiquempois, M. Douay, G. Mélin, A. Fleureau, S. Lempereur, L. Gasca, *Appl. Optics*, **45**, 8186 (2006).
- [7] J. Sun, C. C. Chan, X. Y. Dong, P. Shum, *J. Optoelectron. Adv. Mater.*, **8**, 1593 (2006).
- [8] C. Chen, A. Laronche, G. Bouwmans, L. Bigot, Y. Quiquempois, J. Albert, *Opt. Express*, **16**, 9645 (2008).
- [9] K. O. Hill, G. Meltz, *J. Lightw. Technol.*, **15**, 1263 (1997).
- [10] A. Othonos, K. Kalli, Artech House Inc., Boston-London, (1999).
- [11] P. J. Lemaire, R. M. Atkins, V. Mizrahi, W. A. Reed, *Opt. Eng.*, **30**, 780 (1991).
- [12] M. C. Phan Huy, G. Laffont, V. Dewynter, P. Ferdinand, *Opt. Express*, **14**, 10359 (2006).
- [13] M. C. Phan Huy, G. Laffont, V. Dewynter, P. Ferdinand, P. Roy, J-L. Auguste, D. Pagnoux, W. Blanc, B. Dussardier, *Opt. Lett.*, **32**, 2390 (2007).
- [14] N. J. Florous, K. Saitoh, S. K. Varsheny, M. Koshiha, *IEEE Photon. Technol. Lett.* **18**, 2206 (2006).
- [15] N. Burani, J. Lægsgaard, *J. Opt. Soc. Am. B*, **22**, 2487 (2005).
- [16] C. Caucheteur, M. Debliquy, D. Lahem, P. Mégret, *Opt. Express*, **16**, 16854 (2008).

*Corresponding author: Ivascu_ioana@physics.pub.ro