

# Experimental investigation of the metals vaporization and ionization with microwave used as propellant for ionic propulsion

G. MOGILDEA\*, M. MOGILDEA

*\*Institute of Space Sciences, 409<sup>th</sup> Atomistilor Street, PO Box MG-23, RO 077125, Magurele, Ilfov, Romania*

In this paper we present an experiment which demonstrates the use of metals atoms (in particular, lead) with high atomic mass and relatively low ionization energy as solid propellants in the ionic propulsion. The metal used are directly vaporized and ionized in air, at standard atmospheric pressure using microwaves field.

(Received February 08, 2010; accepted after revision March 12, 2010)

*Keywords:* Cylindrical waveguide, Solid propellant, Microwave field, Lead threads, Ionic propulsion

## 1. Introduction

In this paper, is presented a method for vaporization and ionization of lead, a metal which can be used for ionic propulsion. The lead can be a excellent propellant due to its high atomic mass, relatively low ionization energy and low melting temperature. Metals with such characteristics can be used as solid propellant for electric propulsion in interplanetary missions.

The existing systems microwave thrusters (MT), used so far only gaseous propellants such as (Xe, Kr,  $H_2$ ,  $N_2$ , Ar,  $NH_3$ ) [1-5]. The disadvantages of such gaseous propellants are: the high ionization energy, large storage volume and/or high cost.

According to Xiang Sun et al [6] bulk metals can not be heated directly by a microwave field, because the incident microwaves field is attenuated in a very thin surface layer, and the heating effect caused by induction currents is low. Metals can be heated indirectly using a crucible made of microwave absorbing material where in the metal is placed. The crucible made of Silicon Carbide converts the microwave field in heat used for metal heating.

The bismuth was used as propellant by Makela, J.M et al. (2008). The process started with the discharge on krypton and then switches to bismuth. The propellant used (Bi) is heated in reservoir and then bismuth vapors are ionized and accelerated in discharge chamber by the electric field of the Hall Effect Thruster. [5]

We performed an experiment at room temperature and atmospheric pressure in air to investigate the possibility to produce direct vaporization and ionization of solid lead thread using microwave field. The experiment demonstrates the possibility of using a solid propellant in microwave thruster (MT) or ion thrusters.

## 2. Experimental

The microwave source is a magnetron (type 2M214) which generates a microwave field at a frequency of 2.45 GHz and a power of 800W with repetition rate 50 Hz. The magnetron has the supply voltage -3.5 kV and 50 Hz (rectangular pulses). Power supply for the magnetron provided by a commercial microwave oven. In Fig 1 is presented the electrical scheme of the system.

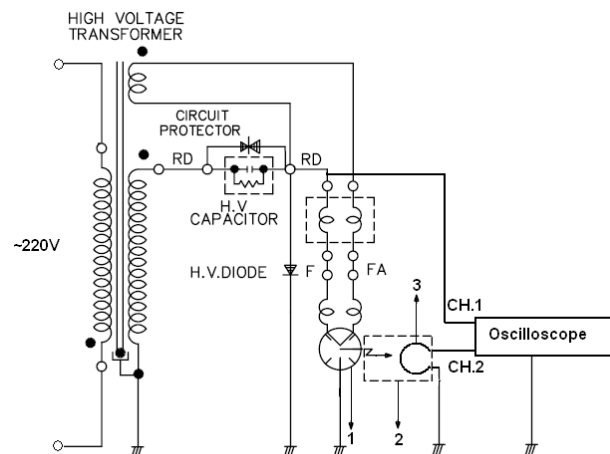

Fig.1. The electrical scheme of the magnetron system: 1- magnetron, 2.- cylindrical waveguide, 3.- inductor.

There is measured the supply voltage from magnetron and the microwave field within the cylindrical waveguide. The signals from power supply and microwave field are measured with an oscilloscope. Because electrical voltage applied on magnetron is almost – 4 kV we used a high voltage probe which attenuates the amplitude of voltage 1000 times.

Within the waveguide is placed an inductor able to measure the wave form of the electromagnetic field. In Fig. 2 are shown the oscillograms recording by oscilloscope which is the supply voltage form of the magnetron and microwave field within the cylindrical waveguide. On the channel 1 of the oscilloscope is measured the voltage applied on magnetron and on the channel 2 the voltage from the inductor.

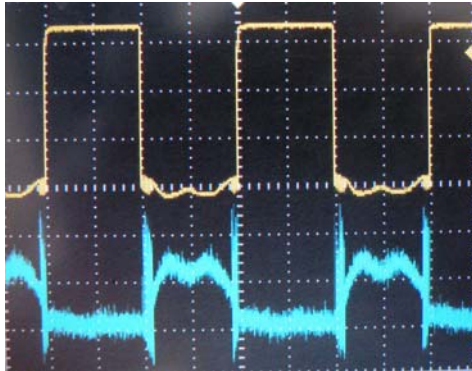

Fig. 2. Oscillograms from supply voltage of the magnetron and microwave field: yellow oscillogram-supply voltage of the magnetron; blue oscillogram- the microwave field forms inside of the waveguide.

Fig. 3 shows the electrical scheme of the experiment which produced the vaporization and ionization of the solid lead sample.

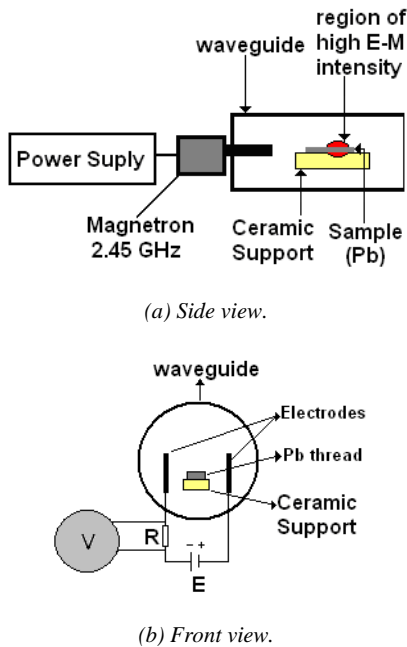

Fig. 3. Electrical scheme of the experiment by vaporization and ionization of the thread lead.

The cavity is a cylindrical waveguide used in  $TM_{011}$  mode propagation and having an internal diameter of 10.7 cm and a length of 8 cm. The dimensions of the cylindrical waveguide we calculated with the formula (1) [1].

$$(f_r)_{nm1}^{TM} = \left( \frac{1}{2\pi\sqrt{\mu\varepsilon}} \right) \cdot \sqrt{\left( \frac{p_{01}}{a} \right)^2 + \left( \frac{l\pi}{h} \right)^2} \quad (1)$$

a - radius of the cylinder (m)

h - height of the cylinder cavity (m)

l - longitudinal mode of the cavity

$p_{01}$  - first zero of the Bessel function,  $J_0$  (equal to approx. 2.405)

$\mu$  - permeability of the media within cavity (H/m)

$\varepsilon$  - permittivity of the media within cavity (F/m)

The indices that describe the  $TM_{nm1}$  modes refer to the number of half wavelength variations in the radial, axial and longitudinal directions. The resonant frequency depends only on the geometric parameters of the cavity which: l - the length of the waveguide and a - the diameter of the waveguide.

Because in the  $TM_{011}$  propagating mode the electric field propagates along the axis of the waveguide, the solid lead thread must be positioned along and as close as possible to that axis. The maximum energy density is obtained inside the waveguide at approximately 6.5 cm from the magnetron antenna.

In the experiment we used lead threads having a diameter of 0.6 mm and a length of around 37 mm. The weight of such a lead thread is around 200 mg.

The solid lead sample introduced was in the waveguide 6.5 cm out of the magnetron antenna on a ceramic support with thread end in high E-M intensity region (Fig. 3.a). It is assumed that the high density of microwave field induces a high density of conduction current on the surface of the sample. This current will heat up the sample until vaporization; further a moreover of the vapor get ionized (Fig. 4). In a  $TM_{011}$  cylindrical waveguide we introduce a solid lead thread having the diameter of 0.6mm and weight 200mg. Under the effect of microwaves of 2.45GHz frequency and an estimated power of 800W, the thread is vaporized and ionized. The lead ions are collected by two parallel electrodes in the waveguide and are put in evidence by the appearance of a voltage at the terminals of resistance R (100Ω).

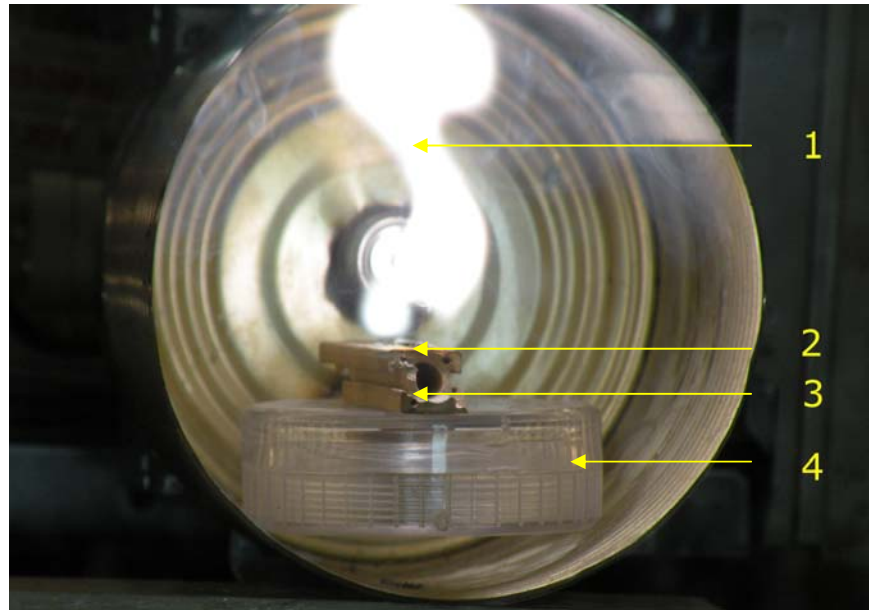

Fig. 4. The lead sample is vaporized and ionized by the microwave field in the cylindrical waveguide  
1- plasma, 2- lead sample, 3- ceramic support, polycarbonate support.

Because the lead sample must be in the centre of the waveguide will raised the position of the lead sample with the polycarbonate support and the ceramic support.

In air, the metal get oxidized and the PbO vapors can be collected on a metallic grid placed position of at the open end of the cylindrical waveguide as well as from the walls of the waveguide.

The electrical scheme from Fig. 3 (b) is used for detection of the ions lead within the waveguide.

Two parallel electrodes made from conductors having areas of  $3 \text{ cm}^2$ . Each are placed to 6.5 cm by antenna. Lead sample situated to half of the distance between two electrodes. The distance between electrodes is 2 cm. When 30V c.c. applied between electrodes, an electrical field by 1.5 kV/m is present within the space between those electrodes.

When the microwave field produces the vaporization and the ionization of the metal, the ion density is measured a voltage around 7 V c.a. The voltage recorded with the voltmeter is proportional to ion density collected by electrodes.

In order to focus the microwave energy on the lead sample, the electric component of the electromagnetic field must be parallel with the electrodes. If the electric component is perpendicular to the electrodes, all the energy will be focused on electrodes. So, in order to have all the energy focused on the lead probe, the magnetron must be rotated by 90 degrees with respect to the initial position. If we repeat the experiment without the lead sample, inside the waveguide, the voltmeter does not show any voltage. So we can conclude that we don't have ionized air between the two electrodes.

In this experiment, the vaporization and ionization processes depend of the electrical conductivity of the sample. The loss factor is defined as:

$$\varepsilon'' = \sigma / \omega \cdot \varepsilon_0 \quad (2)$$

The loss factor increases with the electrical conductivity of the sample.

where:  $\varepsilon''$  is loss factor

$\sigma$  -is the conductivity sample

$\omega = 2 \cdot \pi \cdot f$  is angular frequency

and  $\varepsilon_0$  is vacuum permittivity

The power density dissipated of sample lead by heating can be calculated with equation (3).

$$P = \omega \cdot \varepsilon_0 \cdot \varepsilon'' \cdot E^2 \quad [7] \quad (3)$$

The equations (2) and (3) show that the electrical field component of the microwave field will be attenuated by the sample. Knowing that the magnetron generates a microwave power 800W and  $\sigma_{pb} = 4.8 \times 10^6 \text{ S/m}$ , electrical field will be  $E = 1.29 \times 10^{-2} \text{ V/m}$ . All the energy of the microwaves attenuated by the lead thread is converted into heat.

In Table 1 is shown the percentage of burned\* lead as a function of time. Based on these results, we can conclude that the burning process is linear with time.

Table 1. The percentage of burned\* lead as a function of time.

Figs.	Length of the sample burned* in the microwave field	The weight of the sample burned* in the microwave field	Burning* time (s)
Fig. 5.b	18 mm	97mg	5
Fig. 5.c	24 mm	129mg	10
Fig. 5.d	30 mm	162mg	15

\*) The burning includes both the vaporization and the ionization times.

The burning speed of the lead thread is ~ 6 mm/s.

From Figs. 5 (a-d) is showed the solid lead thread after vaporization.

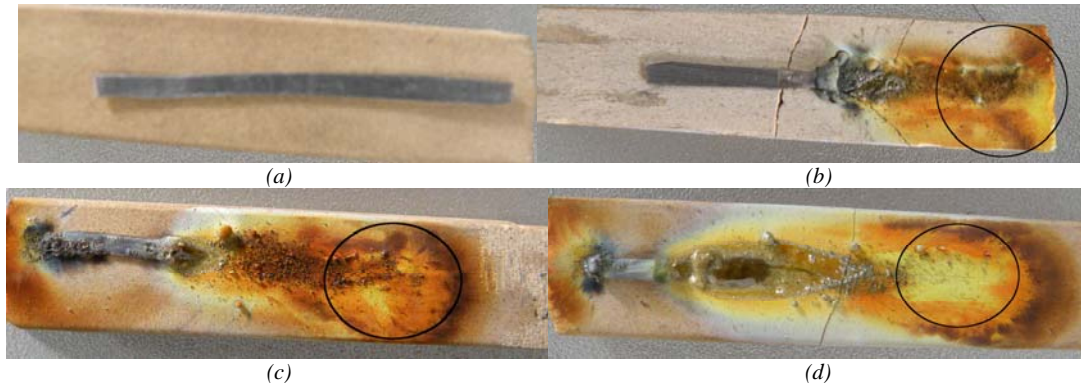

Fig. 5. (a) Sample of lead in microwave field start; (b) Lead sample in the microwave field after switching on 5 s; (c) Lead sample in microwave field at 10s; (d) Lead sample in the microwave field after switching on 15. s.

From Figs. 5 a-d, one can see that as the lead probe is getting further away from the high intensity field region, the combustion is no longer total. The marked area represents the high intensity field region.

### 3. Discussion

It is assumed that the heating of the lead probe takes place due to the electric currents at the surface of the probe.

Our experimental results show that inside the cavity, the energy of the microwaves is sufficient to produce the ionization of the metal, but not of the air. As a result, in the interior of the cavity, will exist only lead ions.

Knowing that the breakdown electrical field in air has a magnitude of approximately 3 MV/m, we can infer that the electric component in air for the microwaves is less than that.

The images in fig. 1a and 1.b show that inside the cylindrical waveguide the energy of the microwave field from the high intensity region vaporizes 100% sample lead and further a percent of the vapors get ionized.

In order to realize the ion thrust propulsion using lead ions, one needs to add a grid system to accelerate the ions. Also, the metal vapors can be ionized by the resulting electric fields of the accelerating grid system.

We believe that this new method of vaporizing and ionizing of a solid propellant can be successfully applied in ion thrusters using microwaves.

A reel of thin metallic wire can be a good substitute for the conventional tank of the other propulsion systems (using liquid or gaseous propellant.)

The vaporization and ionization of the lead with microwave field in this experiment is considered better than the equivalent using bismuth because the lead has a greater electric conductivity, while the other the physical characteristics are similar.

### 4. Conclusions

As a result of the experiment, it was shown that in air at atmospheric pressure and room temperature one can directly vaporize and ionize a lead wire in a microwave field while the air still remains unionized.

The process of vaporizing and ionizing of metallic threads using microwaves allows to get of solid propellants MTs.

### References

- [1] F. J. Souliez, S. G. Chianese, G. H. Dizac, M. M. Micci., Low-power microwave arcjet testing - Plasma and plume diagnostics and performance evaluation, AIAA/ASME/SAE/ASEE Joint Propulsion Conference and Exhibit, 35th, Los Angeles, CA, June 20-24, 1999.
- [2] M. Micci, Low-Power Solid-State Microwave

- Thruster Systems, Spacecraft Propulsion, Third International Conference held 10-13 October, 2000 at Cannes, France. Edited by R.A. Harris. European Space Agency ESASP-465, 203, 2001.
- [3] Y. Takao, H. Kataharada, T. Miyamoto, H. Masui, N. Yamamoto, H. Nakashima, *Vacuum* **80**(11-12), 7, 1239 (2006).
- [4] Y. Takao, H. Masui, T. Miyamoto, H. Kataharada, H. Ijiri, H. Nakashima, Development of small-scale microwave discharge ion thruster, *Vacuum* **73**(3-4), 449 (2004)
- [5] J. M. Makela, D. R Massey, L. B King, *Journal of Propulsion and Power* **1**, 142 (2008).
- [6] X. Sun, J.-Y. Hwang, X. Huang, B. Li, S. Shi, *Journal of Minerals & Materials Characterization & Engineering* **2**, 107 (2005)
- [7] R. Meredith, *Engineers Handbook of Industrial Microwave Heating*, London, 1998.

---

\*Corresponding author: georgemogildea@yahoo.com